

Domestic Hot Water Source (Boiler, Water Heater, or Indirect) and Circulating Pump Control with Setback Schedule

DHW Energy Saver

- *Set Point Adjustment through the Internet via the Heat-Timer ICMS web site*
- *Connected to the Platinum control to add Remote Control, Logging, and Alarming*
- *Provides a 7 Day Peak and Light Load Schedule*



Description:

The (Domestic Hot Water) DHW Energy Saver Operates a Domestic Hot Water Boiler and/or a Circulating Pump to Save on Energy.

- **Save fuel by optimizing equipment runtime.** It does that by having two separate set point differentials. One for peak periods and the other for light load periods.
- **View and adjust setting remotely.** The DHW Energy Saver operation is well integrated in the Platinum control it connects to. The user can set all the DHW Energy Saver parameters on the Platinum control or on the Internet using the Heat-Timer ICMS web site (<http://www.htcontrols.com>).
- **View and export its operation history through the Internet.** Each of the supply and return sensors (provided with the control) or the boiler and circulating pump relays status can be graphed into an Internet Custom History. The history can be viewed on the ICMS web site. In addition, this data can be automatically exported to any e-mail in a spreadsheet or database format.
- **Multi Peak and Light Load Schedule.** The schedules provide 7-day peak and light load periods.

The DHW Energy Saver connects to a Heat-Timer RINet Platinum control (all MPC, MPCQ, HWR, HWRQ, SRC RINet Platinum controls with software version 7.05 or higher) to operate a DHW boiler and/or a DHW circulating pump based on two set points. One set point is for the boiler and the other is for the pump. Two sensors, connected to the Platinum RINet control are used. Aux Temp 0 sensor measures the domestic hot water boiler supply temperature and is installed on the boiler output. Aux Temp 1 sensor measures the domestic recirculating line return temperature. Each of the supply and return temperatures have a Set Point and a Peak and Light Differentials. This offers better operation and savings than having two separate set points. As the goal is to reduce boiler/water heater and pump operation during light periods. That can be achieved by having slightly longer boiler/water heater run periods and longer off periods using a larger differential.

The Platinum control has a separate DHW Energy Saver weekly Day/Night schedule that can be set using the Platinum control or the Internet ICMS web site. It offers 4 peak and 4 light load periods for each day of the week. When in the peak period, the Platinum control will use the Peak Differential setting. When in the light usage period, the Platinum control will use the Light Differential setting. The Light Differential must be greater than the Peak Differential to provide slightly longer boiler or pump runtime and a much longer boiler or pump off time.

DHW Energy Saver

Item **Part #**
DHW Energy Saver **926769-00**

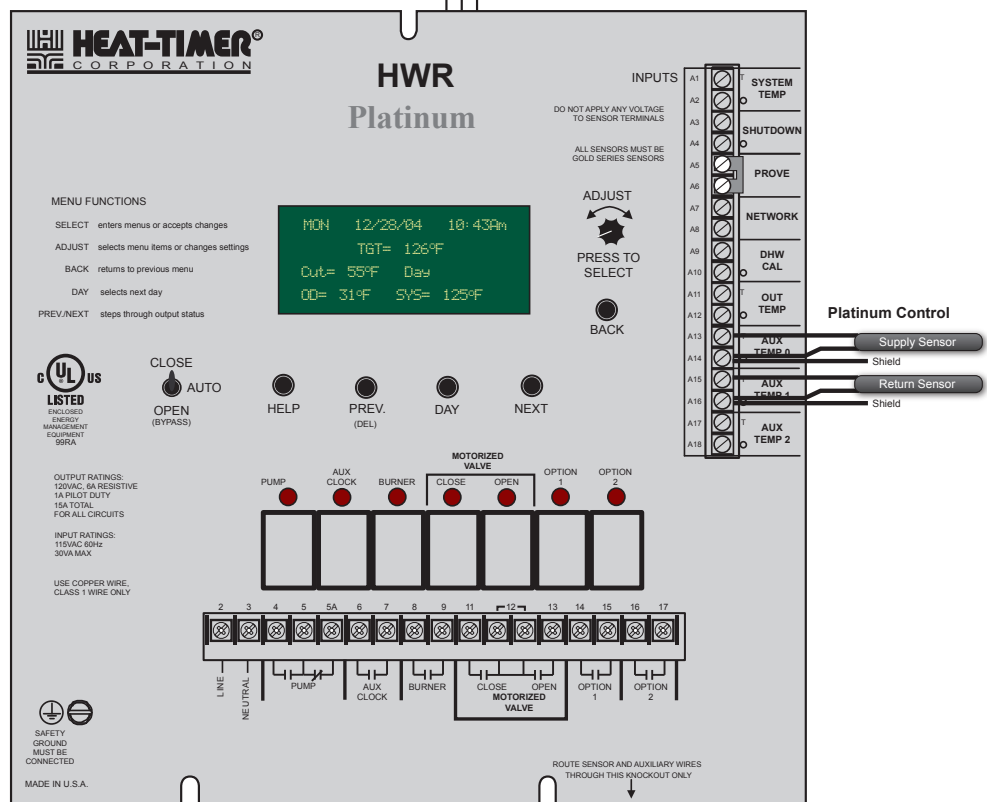
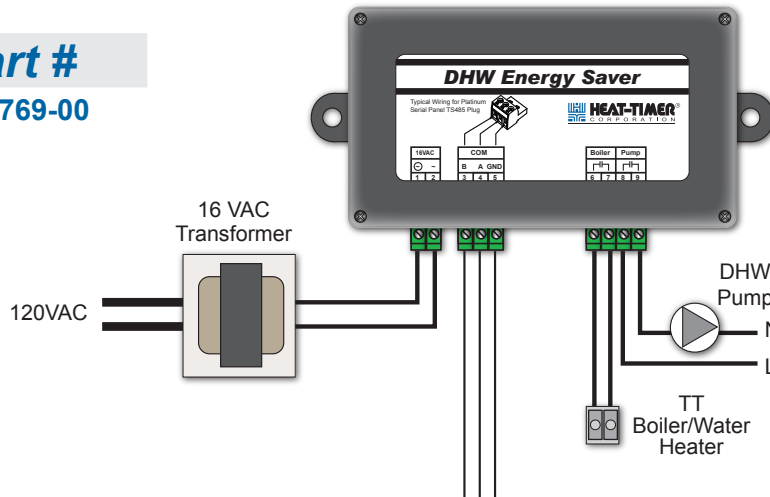

ISO 9001:2008
 CERTIFIED

Specifications:

Voltage Input	16 VAC (transformer provided minimum 10VA)
Output Relays	2 N.O. (SPST). Each a maximum 1/8 HP pump or 6 Amp resistive load at 120 VAC/60 Hz
Outputs	DHW boiler/water heater and DHW pump
Communication	RS485 (3-wire A, Ground, and B)
LEDs	4 (1 Power (Red), 2 Relay Outputs (Red), 1 communication (Green))
Sensors	2 Standard Brass Tube Sensors are provided (Boiler sensor : Aux Temp0, Pump sensor : Aux Temp1)
Well	3/8" x 1/2" NPT well is provided
Dimension	.6-3/4" x 3-5/8" x 1"
Weight	1 Pound

056180-00B

