

# HEAT-TIMER®

## INSTALLATION AND OPERATION INSTRUCTIONS

# Wireless Network Manager (NM) and Wireless Transceiver (TRV)

## FOR PLATINUM CONTROLS WITH COMMUNICATION

The New Heat-Timer Wireless Network Sensor System is designed to be utilized in a variety of large buildings, garden apartments, and in retrofit applications, giving both the accuracy and flexibility required to monitor those buildings' temperatures. The system will ease the installation of space sensors in buildings where it would be difficult or cost prohibitive utilizing other means. Thus, allowing Heat-Timer Platinum controls with communication access to the wireless sensor data. The values read from the wireless system are used by the Platinum controls for monitoring, fine-tuning its operation, and logging its data.

The primary integral components of the system are: the Network Manager (NM), the Transceivers (TRV), the Wireless Sensors (SNR), and finally, the Wireless Programmer (WP). The SNRs communicate their information to a nearby TRV or NM. The TRV transmits the information down either to another TRV or to the NM. The NM communicates all the data it receives to the Platinum control. The WP is the tool used to map, configure, diagnose, and troubleshoot the Heat-Timer Wireless Network System.

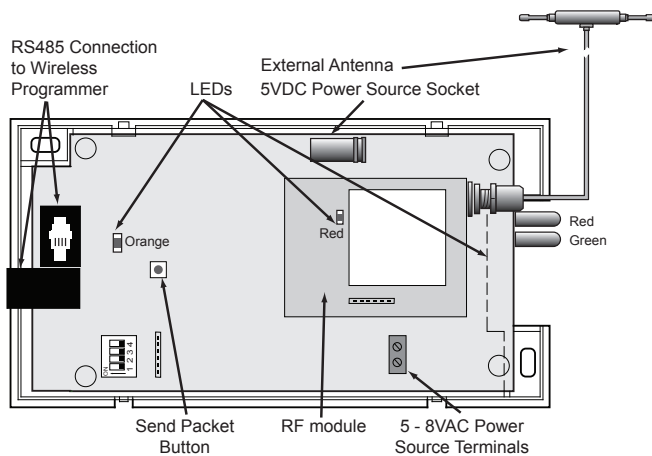

Wireless NETWORK MANAGER

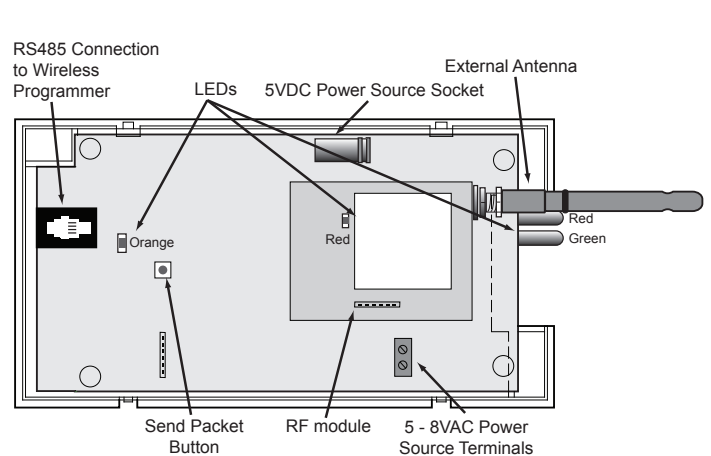

Wireless TRANSCEIVER

*This equipment has been tested and found to comply with the limits for a class B digital device, pursuant to part 15 of the FCC Rules. These limits are designed to provide reasonable protection against harmful interference in a residential installation. This equipment generates, uses, and can radiate radio frequency energy and if not installed and used in accordance with the instructions, may cause harmful interference to radio communications. However, there is no guarantee that interference will not occur in a particular installation. If this equipment does cause harmful interference to radio or television reception, which can be determined by turning the equipment off and on, the user is encouraged to try to correct the interference by one or more of the following measures:*



- Reorient or relocate the receiving antenna.
- Increase separation between the equipment and wireless components.
- Connect the equipment into an outlet on a circuit different from that to which the wireless components are connected.
- Consult the dealer or an experienced radio/TV technician for help.

# INSTALLATION

## MAPPING/SURVEY

- A wireless survey of the building must be done before installing any wireless component. The survey involves the use of at least two WPs (Wireless Programmers).
- Each of the WPs is set to emulate a different wireless component. Then, test communication and signal strength between the different wireless components. Both signal strength readings (RSSI) should be above 55 for a reliable connection.
- If signal strength was not achieved, replace the WPs' short antennas with the rubberized swivel antennas. Then redo the test. In situations where the signal has to go a large distance between buildings, use the outdoor antennas instead (see Installing the Antennas on page 7).
- Upon receiving good continuous signal strength, *MARK* the two locations of the WPs and the direction and type of antenna used. These will be the locations of the wireless components' installation. To set the WP to emulate each component, follow the steps.

### Setting the WP System ID

- Make sure that the WP is fully charged.
- Power the WP on. That should turn its LED to Green.
- Select **WP.Setup Mode** from the Main menu by pressing the (Enter / ) button. Then, type a System ID or press the (Down / ) button to select a random ID. To accept the new System ID press the (Enter / ) button. Then, press the **F** button to load it into the WP.
- This will be followed by the Emulation Mode menu.
- Remember to record the System ID to help you in setting up the next WP to the same System ID.

```
-WP.SETUP mode
SYSTEM ID# C9E5
[UP] delete
[DOWN] pick
```

```
*CONFIG. MODE[9]
WP.Sys Id# C9E5
[F] to load
```

```
-WP.Setup mode
> Emulate TRV
  Emulate SNR
  Emulate NM
```

**⚠ WARNING**

**DO NOT use 0000 as a System ID to avoid errors in operation. The Heat-Timer Wireless Network components can communicate only if they have the same System ID.**

### Emulating Network Manager (NM)

- After setting the System ID on the WP, the Emulation menu will display.
- Select **EMULATE NM** and Press the  followed by the **F** to proceed with the NM Emulation. An **ACK** (Acknowledge) will appear on the third line of the display acknowledging the acceptance by the WP.
- Press the **Mode** to enter the **SURVEY MODE**, which appears on the top of the display. The second display line will read **NET MANAGER**.
- In the Survey Mode, no data will be available on the WP display.

```
-WP.Setup mode
EMULATE NM
[F] to load
```

```
-WP.Setup mode
Setup complete
[Mode] to exit
```

### Exit NM Emulation:

- To exit this mode, press the **Mode** to go back to the System ID# Setup.

```
SURVEY MODE
NET MANAGER
```

**⚠ ALERT**

**To exit the NM Survey Mode the user MUST Select to Emulate a TRV or a SNR first.**

```
-WP.SETUP mode
SYSTEM ID# C9E5
[UP] delete
[DOWN] pick
```

### Emulating Transceiver (TRV)

- After setting the System ID on the WP, the Emulation menu will display.
- Select **EMULATE TRV** and Press the **[Enter]**. The option for the transmission power will follow.
- A TRV will default to 100mw transmission power. Do not change this value. Press the **[F]** to accept and proceed to the Sniff/Detect RSSI menu.
- Select **DETECT RSSI** using the **[Enter]** button followed by the **[F]** to accept.
- Press the **[Mode]** to go to the main menu.
- Select **Auto Mode** using the **[Down]** or **[Up]** buttons. Then press the **[Enter]** button to accept. Within a few seconds, signal strength data should display.
- The numbers below the **MASTER** and **WPROG** represent the signal strength received by each of the components from the other component. That is, the number below **MASTER** represents how well the **MASTER** received current **WPROG** signal.
- The fourth display line contains **T01** which represents the master's ID. A **00** represents the NM. Any ID that starts with the **T** or **R** represents a TRV.
- The **NEW 01A** represents the next TRV ID upstream available.

```
-WP.Setup mode
EMULATE TRV
>100mw 200mw
[F] to load

Accept 100mw [F]

-WP.Setup mode
SNIFF
> DETECT RSSI

Accept Detect RSSI [Enter]

-WP.Setup mode
DETECT RSSI
[F] to load

Enter the Detect RSSI [F]

Config devices
Get device data
WP.Setup Mode
>Auto Mode

Enter Auto Mode [Enter]

AUTO MODE
MASTER WPROG
65 62
T01 NEW 01A
```

### SETTING THE WIRELESS CONFIGURATION

For the TRVs to function in a wireless system, each must be assigned a Net#. The Net# determines the path the information is passed on from one TRV to the next, all the way down to the NM. The NM has a fixed 00 as the Net#.

The main concept is that the NM can communicate upstream directly to a maximum of two TRVs. Each of the two TRVs will represent a main path for the data to travel. The communication can be either vertical or horizontal. The first main path TRVs will have odd Net#. The first TRV (T01) on that first main path will be set to communicate to the NM. The second TRV up the same path will be T03. It will communicate its data to T01 and so on. The second primary path TRV will have a Net# of T02. The second TRV on that odd path will have a Net# of T04.

Each of the TRVs on the main path can have sub-path with the same TRV prefix but with an added suffix letter to represent the TRV sub path location. That is T03B will communicate its data to T03A which will communicate its data to T03 on the main path.

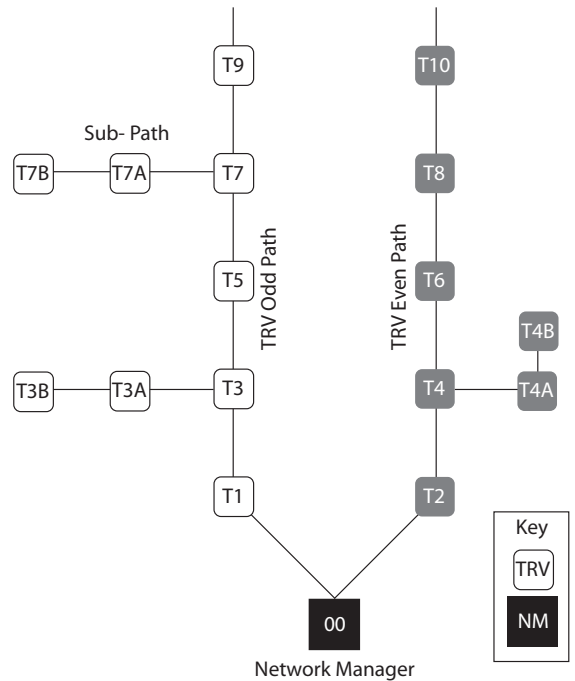

### Setting the TRV Net #

- Make sure that the WP is fully charged.
- Power the WP on. That should turn its LED to Green.
- Select **Configure devices** from the Main menu by pressing the **[Enter]** button.

```
>Config devices
Get device data
WP.Setup Mode
Auto Mode
```

- Then, scroll the menu using the **▼** or **▲** buttons to select **TRV Net** Add menu option.
- Use the **▼** or **▲** buttons to change the TRV Network Address. Make sure the TRV Network number is not repeated within the same wireless network.
- Use the **0**, **A**, or **B** buttons configure the Suffix of the TRV Network Number. The Suffix will determine the TRV sub-path.

**Accept Config Devices** **◀**

```
*CONFIG. MODE[4]
Wake up Period
RF out
>TRV Net Add
```

```
*CONFIG. MODE[4]
TRV NET#01 0
[UP/DWN] [0/A/B]
Press [F] to Load
```

## CONFIGURING THE NETWORK MANAGER (NM) AND TRANSCEIVER (TRV) SYSTEM ID

Each wireless network should have a unique System ID. The System ID enables all wireless components with the same ID to communicate to each other. The WP is the only tool used to configure all system components and their parameters.

### Setting the Wireless TRV, or NM System ID

- After setting the WP to the System ID, you will need to configure the wireless components, TRV and NM, with the System ID.
- When in the Emulation menu (**WP Setup Mode**) press the **Mode** button to return to the main menu.
- Select **Config devices** from the Main menu by pressing the **◀** button. Then, select **System Id** from the list by pressing the **◀** button. This will display the System ID configured into the WP.
- Make sure that the phone cable is connected to the WP and the wireless component to be programmed.
- Press the **F** button to load the System ID into the wireless component.
- This will display **ACK** briefly on the third line of the display acknowledging the wireless component acceptance of the new System ID.

**Exit to Main Menu** **Mode**

```
>Config devices
Get device data
WP Setup Mode
Auto Mode
```

**Accept Config Devices** **◀**

```
*CONFIG. MODE[9]
>System Id
Reset Sensor
POWER dwn SNR
```

**Select System ID** **◀**

```
*CONFIG. MODE[9]
WP Sys Id# C9E5
[F] to load
```

To load the System ID **F**

## TESTING AND OPERATING WIRELESS COMPONENTS

### Network Manager (NM) Operation

- The NM is the primary component in the Heat-Timer Wireless Network Sensor System. No wireless network will exist without one. It collects the wireless network data and information and communicates it to the Heat-Timer Platinum control. In addition, the NM can communicate directly to multiple sensors. The smallest wireless network should contain one NM and at least one SNR.
- Each of the NM and TRVs can communicate to a maximum of two upstream TRVs. The NM upstream TRVs should be the main wireless paths for the system. One path will have all the TRVs Net#s as odds (T01, T03, T05, T07, ...) while the other path will have all TRVs Net#s as evens (T02, T04, T06, T08, ...). The information is passed on from the TRV with the highest Net#s to the lower one on the same path. That is, T07 will pass its data to T05. Then, T05 will pass its data and T07 data to T03 who will pass it on to T01. The T01 TRV will then pass all the data to the NM. The same applies to the second primary path with even Net#s. The NM will transmit all the data using its RS485 connection to the Platinum control.

- The wireless network can function independently from the Platinum control. However, the data will not be utilized until a Platinum control is connected and the wireless components are configured on the ICMS website (<http://www.htcontrols.com>).
- The NM is powered using either an 8VAC dedicated transformer (supplied) connected to the two terminals or using a 9 - 12VDC adaptor plugged into the power socket. Only one power source can be used at a time with the NM.
- When programming the NM using a WP, no additional power source is needed as the WP can source the power to the NM when they are connected together and the WP is powered.

### ⚠ WARNING

The NM and TRVs can accept only one power source. Either an 8 VAC or a 9 - 12 VDC. The use of more than one power source will damage the NM or TRVs and possibly injure the operator. During configuration of TRV or NM with the WP, no additional power source is required as the WP can power the NM or TRV being configured.

### Locating the NM

- The NM must be connected to the Heat-Timer Platinum control using RS485 (furnished with a standard 6 Ft cable). The distance between the two should not exceed 50ft. That gives the installer the opportunity to place the NM antenna on other floors to overcome signal strength reduction when penetrating boiler rooms.
- The NM is powered from an external source using the supplied 8 VAC dedicated transformer. Locate the NM within close proximity to a power source to reduce the wiring.
- The NM external antenna must be placed in an area where it will be able to communicate effectively with the TRVs and SNRs. The NM comes with an external T-antenna that is equipped with a 6 Ft cable. For additional Antenna options, see Installing the Antenna section on page 7.
- As with all wireless components, for the NM to function within a wireless network, it must be programmed with the System ID, using the Wireless Programmer (WP). A NM with no System ID, as with new one from the factory, will have all LED lights blinking when powered up.
- To save time after completing the wireless installation and configuration on the web, press the NM button to send all the wireless devices' data instantly.

### LED Indication

- **Red RF Module LED:** Blinks when transmitting data.
- **Red Main LED:** Blinks when transmitting data.
- **Orange Main LED:** Blinks to indicate NM sending data to the Platinum Control.
- **Green Main LED:** Blinks to indicate NM is receiving TRVs and SNRs data.
- **All LEDs:** When all LEDs are blinking, it indicates NM requires System ID to be configured. This is the default mode from the factory before configuring the System ID.

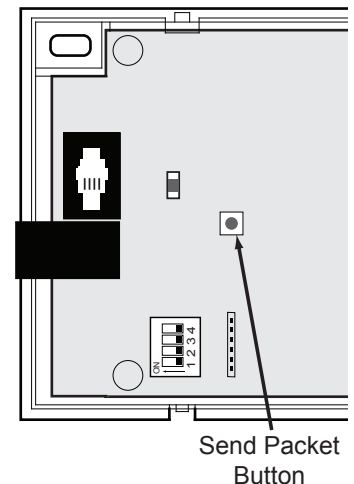

### Transceiver (TRV) Operation

- The TRV can be used as a range extender for the Heat-Timer Wireless Network Sensor System. A TRV can communicate to a maximum of two upstream TRVs and only one downstream. One of the upstream TRVs will represent the main path and will have a Net# that is numerically consecutive to the current TRV's Net#. If the current TRV Net# was T05, the next upstream TRV will have a Net# of T07. The second upstream

TRV Net# will branch of the main path with a Net# of T05A. On the other hand, a TRV can communicate to only one downstream TRV or NM. The TRV Net# is programmable using the WP (See path diagram on page 3).

- The TRV is powered using either an 8VAC dedicated transformer connected to the two wire terminals or using a 9 - 12VDC adaptor plugged into the power socket. Only one power source can be used with any TRV at a time.
- When programming the TRV using a WP, no additional power source is needed as the WP can source the power to the TRV when they are connected together and the WP is powered.

### Locating the TRV

- The TRV gets power from external power sources. Locate the TRV within close proximity to a power source that will reduce the wiring.
- The TRV must be heard by the downstream TRV or NM (The Red Main LED is blinking and not steady.)
- For the TRV to function within a wireless network, it must be programmed with the System ID and Net#, using the Wireless Programmer (WP). A TRV with no System ID, as with new wireless components from the factory, will have all LED lights blinking when powered up.
- After configuring the TRV on the ICMS website, pressing the TRV button will flash the Orange LED as it sends a packet of information to the downstream TRV or NM.
- The TRV can utilize a variety of antennas. See Installing the Antenna section on page 7.

### LED Indication

- **Red RF Module LED:** Blinks when transmitting data.
- **Red Main LED:** Blinks when transmitting data. If steady on, the TRV cannot find a downstream TRV or NM.
- **Orange Main LED:** Steady ON when TRV is in Install Mode. Blinks
- **Green Main LED:** Blinks to indicate TRV is receiving NM, TRVs, or SNRs data.
- **All Main LEDs:** When all main LEDs are blinking, it indicates TRV requires System ID to be configured. This is the default mode from the factory before configuring the System ID.

## MOUNTING THE NM AND THE TRV

- For best performance, make sure that when installing the TRV its antenna direction matches the survey's antenna direction.
- The NM or TRV can be mounted on any wall or ceiling. Mount the NM or TRV away from excessive heat, cool, and humidity sources as in front of a heating or cooling units or close to windows.
- The ambient temperature at the NM or TRV location should be between 32°F and 150°F.
- Open the NM or TRV Cover by inserting a narrow flat screwdriver in each of the two rectangular opening at the bottom of the enclosure cover. Then, pry it open without excessive force.
- Mount the NM or TRV base on the wall using the provided screws and the mounting holes on the base.
- Connect the power source to the NM or TRV power terminals.
- When connecting one of the removable antennas to the NM or an external TRV, screw the antenna cable to the RF Board.
- Replace the NM or TRV cover.

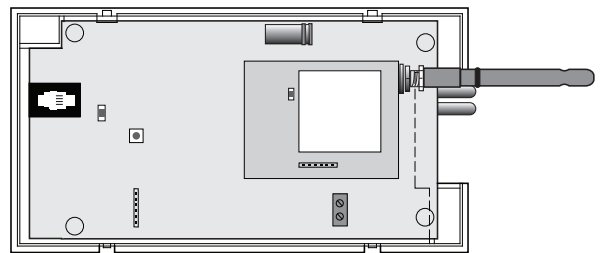

## INSTALLING THE ANTENNA

- When surveying for a wireless network, it is important to note that the TRVs with external antennas will cover a larger distance than the TRVs with internal antennas. However the following must be observed.
- When installing the wireless system in tall buildings where several TRVs are needed to reach the upper floors, have the antennas of all the wireless components mounted horizontally and parallel to each other. This will insure maximum reception and transmission while reducing the number of TRVs used.
- However, when installing the wireless system in garden apartments where several TRVs are needed to reach large horizontal distances, have the antennas of all the wireless components mounted vertically and parallel to each other. This will insure maximum reception and transmission.
- If the horizontal distance is too large for an External antenna, use the Outdoor Antenna. It is designed to be mounted outdoors where it send and receive a signal across large horizontal distance as in between buildings. The Outdoor Antenna can replace the External Antenna on a NM or a TRV.

### NM T-Antenna

- The NM has a default external T-shaped antenna with a 6 Ft. cable
- Locating the T-antenna to have the best reception signal is critical to the network communication. Locate the T-antenna closer to the two main path TRVs. Antennas should be mounted indoors.
- To achieve the best reception all antennas of all the wireless devices should be parallel to each other.
- The T-antenna can be affixed to a wall using a plastic head cable tie.
- Screw the antenna end to the NM round socket.

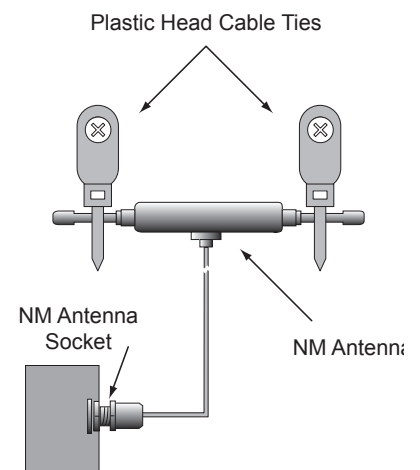

### ⚠ ALERT

RF signal transmission and reception will increase and decrease based on the surrounding environment. For better reception, locate the wireless components and their antennas away from metal doors and large trees.

### External TRV Antenna

- The TRV comes with one of two antenna styles. A rubberized antenna, which comes with the External TRV. This antenna can be rotated around a swivel point direct it to achieve a better signal strength. Alternatively, the TRV can come with a built-in antenna (Internal Antenna).
- The External rubberized swivel antenna requires screwing the antenna to the TRV round socket.
- To achieve the best reception all antennas of all the wireless devices need to be parallel to each other.
- Also, only TRVs with External antennas can be upgraded to an Outdoor Antenna. See Outdoor Antenna on page 8.

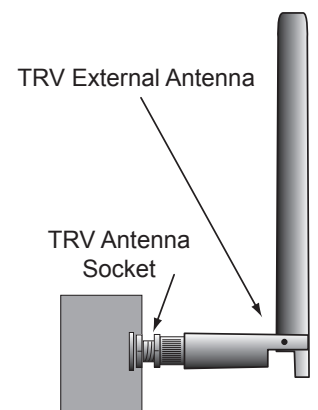

### Internal TRV Antenna

- The built-in antenna does not require any modification or mounting. Its direction is parallel to the TRV's longest edge.
- Note that TRV with Internal built-in antennas cannot be upgraded to TRV with External antennas.
- To achieve the best reception all antennas of all the wireless devices need to be parallel to each other.

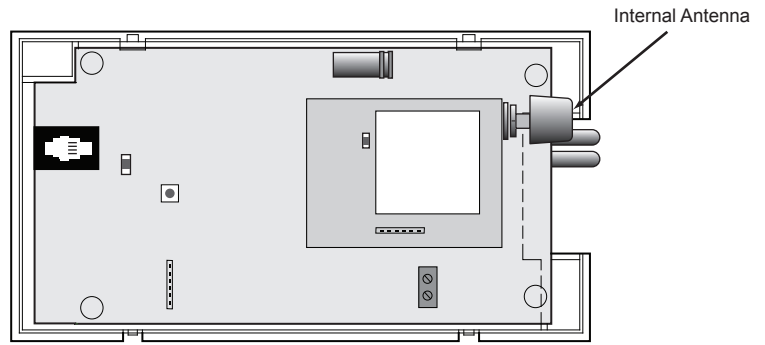

### Outdoor Antenna (Optional)

- This antenna can replace a TRV External or NM Antenna.
- The Outdoor Antenna is primarily used to communicate wireless data between distant points. This makes it ideal in garden apartment installations where the NM is in one building while the first TRV is in another distant building.
- To cover a large distance as in garden apartments or wide apartment buildings, use two Outdoor Antennas each connected to a wireless TRV or NM.
- To achieve the best reception all antennas of all the wireless devices need to be parallel to each other.

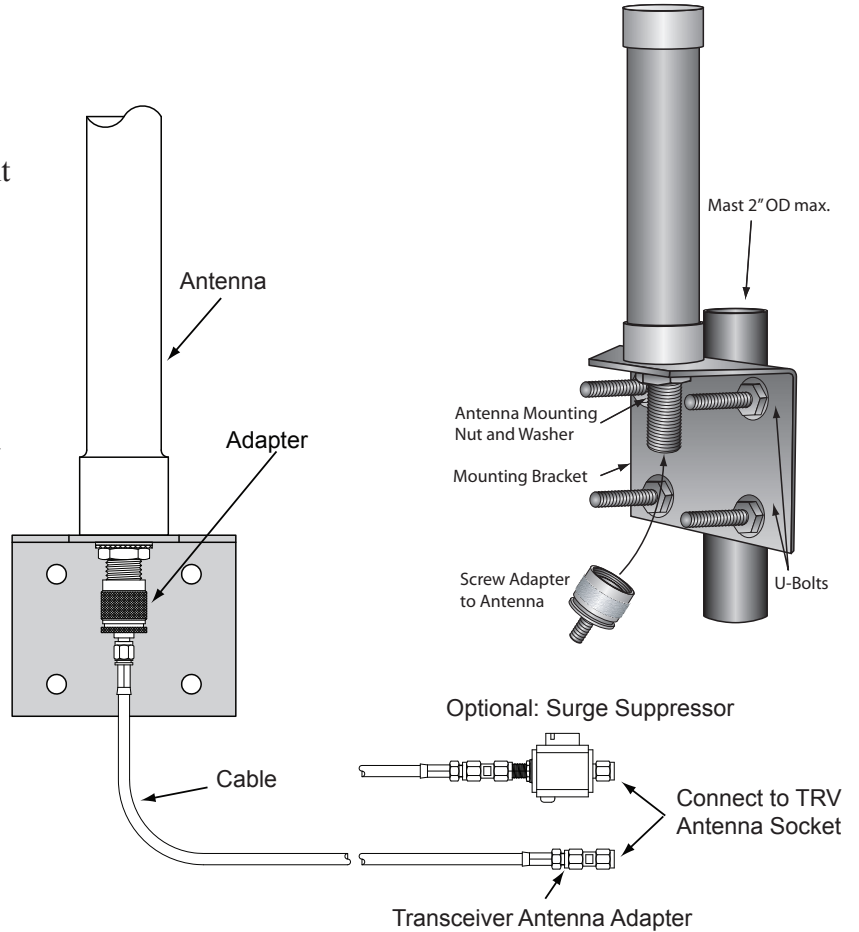

## POWERING THE NM OR THE TRV

- The NM or the TRV can accept only one power source. It can be powered by either 8VAC or 9 - 12VDC.
- During configuration, the WP can power the NM or the TRV when connected using the RS485 phone cable.
- The 8 VAC dedicated transformer supplied can be wired to the NM or the TRV terminals.

**⚠ WARNING**  
**DO NOT share the NM or TRV transformer with other devices. This may cause problem in the wireless operation or permanent damage to the equipment.**

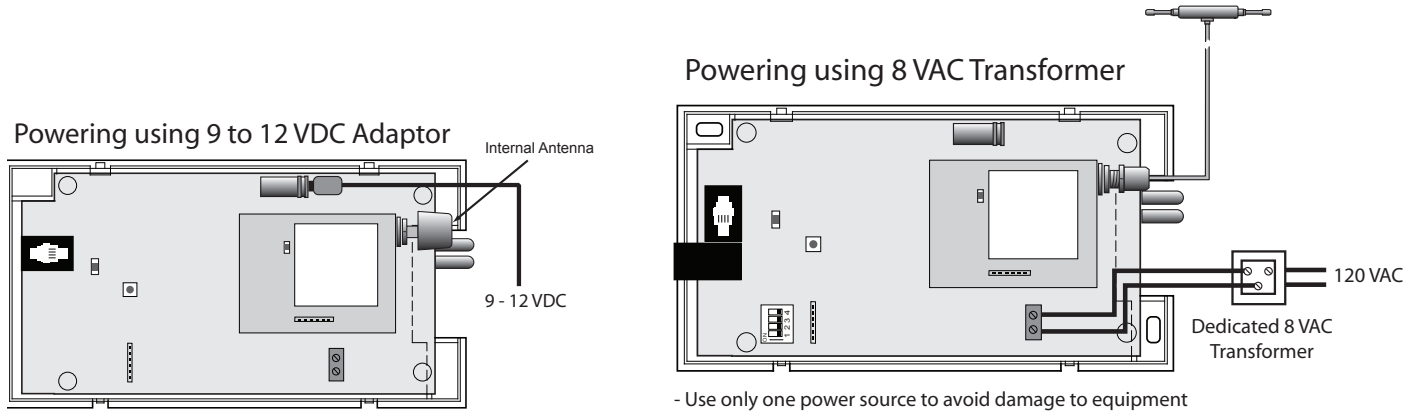

## CONNECTING THE NM TO THE PLATINUM CONTROL

- The Wireless Network Sensor System can function independent of the Platinum control. This way the wireless system can be installed before the Platinum control. However, the data will not be utilized until the wireless components are configured on the web ICMS (<http://www.htcontrols.com>).
- Use cable (HT#900035-00) to connect the NM RJ485 on the Ethernet board on the back of the Platinum control. Connect the cable modular end to the NM.

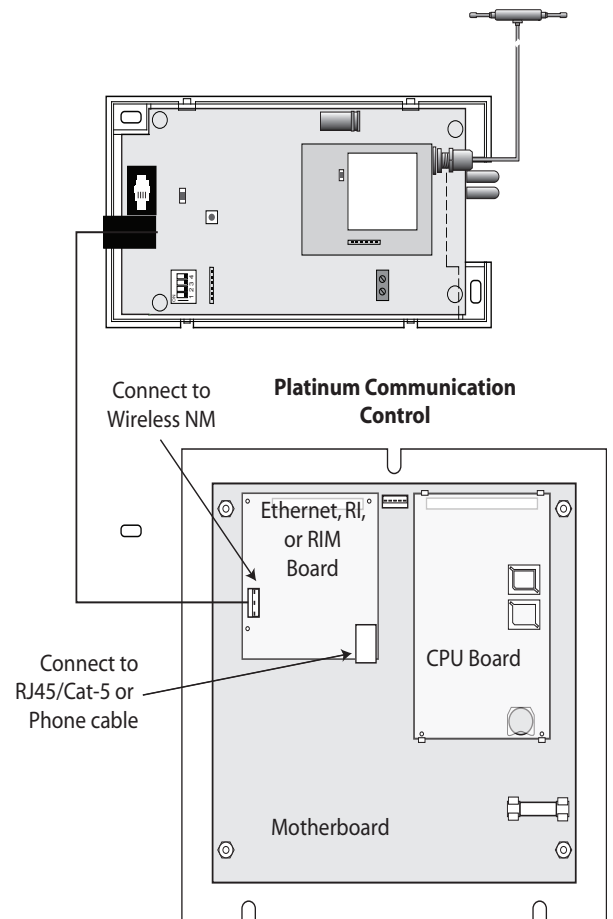

## CONFIGURING THE NM AND TRV ON THE ICMS WEBPAGE

- The Wireless Network Sensor System data can only be read by any Platinum control with Internet or Visual Gold Plus communication package.
- If using a Visual Gold Plus package, only the wireless sensors can be configured on the computer.
- If using the Internet Communication ICMS web system (<http://www.htcontrols.com>), each of the NM, TRVs must be configured to see its own data. The Device ID, Type, and Floor are required to configure any of the wireless components.
- The easiest way to configure multiple wireless devices is to log on to your account as a Full Rights user. Then, start with the *Functions* button and press *Mass Device Changes*. Select the Platinum control and then select the *Wireless Sensor/TRCVRS* button.
- List all your wireless devices using the Device ID and Floor Number. Try to provide a meaningful name to each device to help in identifying them later in other WebPages as well as in troubleshooting.

Network / MIG Sensors    Wireless Sensors / TRCVRS

Add  blank 'Wireless' template(s) to the list to configure.

#	Device ID	Device Name	Type	Floor	Location
<input checked="" type="checkbox"/>	0000 0000 0AAA	NM	Transceiver	BR	
<input checked="" type="checkbox"/>	0000 0000 0ABC	TRV01	Transceiver	2	
<input checked="" type="checkbox"/>	0000 0000 0ACD	TRV03	Transceiver	5	

## TROUBLESHOOTING

- The Wireless Network System can mostly be diagnosed over the web using the *Wireless Diagnostic View* that can be accessed from the *3D building* page.
- Primarily, the signal strength (RSSI) is the most important information. It measures the transmission and reception signals between the current device and it's downstream parent. If that measurement is below 55%, you can either move the device to a better location or replace it with another with an external or outdoor antenna.

Name	ID#	Floor	Current Value	Battery	TRCVRAddress	RSSI Sensor	RSSI Master
NM	00000000AAA	BR			NM		
TRV01	00000000ABC	2			1		62%
TRV03	00000000ACD	5			3		79%
32-3B	000000003E7	3	78 °F	<input type="button" value="Good"/>	3	51%	51%
32-4B	00000000ADD	4	80 °F	<input type="button" value="Good"/>	3	62%	62%
32-4D	00000000DD0	4	71 °F	<input type="button" value="Good"/>	3	58%	59%
36-F3	00000000018	3	79 °F*	<input type="button" value="Good"/>	1	74%	79%

# WARRANTY

**WARRANTIES AND LIMITATIONS OF LIABILITY AND DAMAGE:** Heat-Timer Corporation warrants that it will replace, or at its option, repair any Heat-Timer Corporation manufactured product or part thereof which is found to be defective in material workmanship within one year from the date of installation only if the warranty registration has been properly filled out and returned within 30 days of the date of installation. Damages to the product or part thereof due to misuse, abuse, improper installation by others or caused by power failure, power surges, fire, flood or lightning are not covered by this warranty. Any service, repairs, modifications or alterations to the product not expressly authorized by Heat-Timer Corporation will invalidate the warranty. Batteries are not included in this warranty. This warranty applies only to the original user and is not assignable or transferable. Heat-Timer Corporation shall not be responsible for any maladjustments of any control installed by Heat-Timer Corporation. It is the users responsibility to adjust the settings of the control to provide the proper amount of heat or cooling required in the premises and for proper operation of the heating or cooling system. Heat-Timer Corporation shall not be required to make any changes to any building systems, including but not limited to the heating system, boilers or electrical power system, that is required for proper operation of any controls or other equipment installed by Heat-Timer Corporation or any contractor. Third Party products and services are not covered by this Heat-Timer Corporation warranty and Heat-Timer Corporation makes no representations or warranties on behalf of such third parties. Any warranty on such products or services is from the supplier, manufacturer, or licensor of the product or service. See separate Terms and Conditions of Internet Control Management System (“ICMS”) services, including warranties and limitations of liability and damages, for ICMS services.

THE FOREGOING IS IN LIEU OF ALL OTHER WARRANTIES, EXPRESS OR IMPLIED AND HEAT-TIMER CORPORATION SPECIFICALLY DISCLAIMS ANY AND ALL WARRANTIES OF MERCHANTABILITY FOR A PARTICULAR PURPOSE. UNDER NO CIRCUMSTANCES SHALL HEAT-TIMER CORPORATION, ITS AUTHORIZED REPRESENTATIVES, AFFILIATED OR SUBSIDIARY COMPANIES BE LIABLE FOR SPECIAL, CONSEQUENTIAL OR INCIDENTAL DAMAGES, EXCEPT AS SPECIFICALLY STATED IN THESE TERMS AND CONDITIONS OF SALE. THE SOLE REMEDY WITH RESPECT TO ANY PRODUCT OR PART SOLD OR INSTALLED BY HEAT-TIMER CORPORATION SHALL BE LIMITED TO THE RIGHT TO REPLACEMENT OR REPAIR F.O.B. FAIRFIELD, NJ. HEAT-TIMER CORPORATION SHALL NOT BE LIABLE OR RESPONSIBLE FOR LOSS OR DAMAGE OF ANY KIND RESULTING FROM DELAY OR INABILITY TO DELIVER FOR ANY REASON, INCLUDING BUT NOT LIMITED TO FIRE, FLOOD, LIGHTNING, POWER FAILURE OR SURGES, UNAVAILABILITY OF PARTS, STRIKES OR LABOR DISPUTES, ACCIDENTS AND ACTS OF CIVIL OR MILITARY AUTHORITIES.

03122010

### Network Manager (NM) Specifications

**Power Input:** . . . . . 8VAC (Transformer supplied) /9-12VDC  
**Transmission/Reception:** . . . . . External T-Antenna  
**Buttons:** . . . . . 1 button  
**LED:** . . . . . 4 LED for status display  
**Programming Interface:** . . . . . RS485  
**Dimensions:** . . . . . .6" x 3-1/8" x 1-3/4"  
**Mounting:** . . . . . Wall/Ceiling Mount  
**Connection to Platinum:** . . . . . RS485  
**Frequency:** . . . . . RF 900MHz FHSS  
**Signal Strength:** . . . . . .25mw to 200mw

### Transceiver (TRV) Specifications

**Power Input:** . . . . . 8VAC (Transformer supplied) /9-12VDC  
**Transmission/Reception:** . . . . . Internal/External Antenna  
**Buttons:** . . . . . 1 button  
**LED:** . . . . . 4 LED for status display  
**Programming Interface:** . . . . . RS485  
**Dimensions:** . . . . . .6" x 3-1/8" x 1-3/4"  
**Mounting:** . . . . . Wall/Ceiling Mount  
**Frequency:** . . . . . RF 900MHz FHSS  
**Signal Strength:** . . . . . .25mw to 200mw

### Outdoor Antenna Specifications

**Frequency:** . . . . . RF 900MHz  
**Rated Wind Velocity:** . . . . . 108MPH  
**Mounting:** . . . . . Vertically outdoors using the provided bracket and adapter  
**Cable length:** . . . . . 15 Ft.