

HEAT-TIMER

INSTALLATION/OPERATING INSTRUCTIONS

RSM

A Control for Under Slab Heating Systems Used to Melt Ice or Snow

How the RSM works...

The RSM is designed to control under slab heating systems to prevent accumulations of ice or snow. To do this, it monitors three temperatures, the outside temperature, the temperature of the fluid going to the slab, and the temperature of the fluid returning from the slab.

The slab must be kept above freezing (32°F) whenever there could be frozen precipitation. Therefore, any ice or snow which falls on the slab will melt immediately. If precipitation is allowed to accumulate before the slab is heated, an effect called bridging can occur. The snow or ice directly in contact with the slab will melt. But the snow above will act as an insulator, reflecting the heat back into the slab. The slab itself will be dry, but the remaining accumulation will melt very slowly. To prevent this, the RSM activates the slab heating system whenever the outside temperature falls below the adjustable outdoor cutoff temperature or whenever the optional external system starter is activated.

Once the slab heating system is activated, the amount of energy entering the slab is determined by the difference between the temperature of the fluid going to the slab (the Slab Supply) and the temperature of the fluid returning from the slab (the Slab Return). The difference between these two is called the Δ (Delta)T or the difference in temperature. The Δ T will be different for each slab composition. The higher the Δ T, the more energy is being input to the slab. If the Δ T is too large, the slab itself can be damaged. The RSM provides a maximum Δ T adjustment which can be set from 5°F to 50°F

The RSM will control a 3-way motorized mixing valve to regulate the amount of heat being supplied to the slab. The motorized valve will mix the heated fluid from the heat source with the fluid returning from the slab. As the slab or its components can be damaged by excessive temperatures, the maximum temperature for the slab supply can be adjusted from 70°F to 180°F. If the Slab Supply temperature reaches this limit, the control will immediately begin to close the valve.

Due to the twin constraints of maximum Δ T and maximum Slab Supply temperature, as well as the nature of under slab heating systems, a typical slab will take many hours to reach melting temperatures. A 24 hour warm-up period is not unusual. The RSM is provided with a Tune adjustment to insure the slab temperature will be sufficient to melt frozen precipitation once the warm-up period has ended. The Tune value compensates for both different slab types and different outdoor weather conditions. After making a change in the Tune value, it is necessary to wait at least several hours before accessing what affect it will have on slab temperatures.

WARNING: This Heat-Timer control is strictly an operating control; it should never be used as a primary limit or safety control. All equipment must have its own certified limit and safety controls required by local code. The installer must verify proper operation and correct any safety problems prior to the installation of this Heat-Timer control.

INSTALLATION

Mounting the control

- Select a location which is indoors, or which is protected from the elements. The control must be protected from extreme heat or cold.
- The RSM is designed to mount on a standard 1900 (4" x 4") electrical box or can be flush mounted on a panel with the extension skirt included.
- Before mounting, bring the power and load control circuit wiring into the 1900 box and connect to the individual wires coming from the back of the control (See Wiring the Power and Wiring the Output).
- Use the two screws provided to mount the RSM to the 1900 box.

Installing the sensors

- All three sensors are interchangeable.
- The sensor wires can be extended up to 500' by splicing with two conductor 18 gauge wire. **Do not run wires in conduit with line voltage.**
- The Outdoor sensor should measure approximately the same outdoor air temperature as the slab will experience. Therefore, mount the sensor away from any doors, windows, exhaust fans, vents, or other possible heat sources. **Keep the sensor out of direct sunlight.** Locate the sensor on the north side of the building or in a similarly shady location.
- The Slab Supply and Slab Return sensors must be installed in 3/8" ID immersions wells (HT #904011 or equivalent).
- The immersion well for the Slab Supply should be put in the fluid going out to the slab, approximately 10' past the heat source.
- The immersion well for the Slab Return should be put in any convenient location where the fluid has returned from the slab.

TYPICAL INSTALLATION

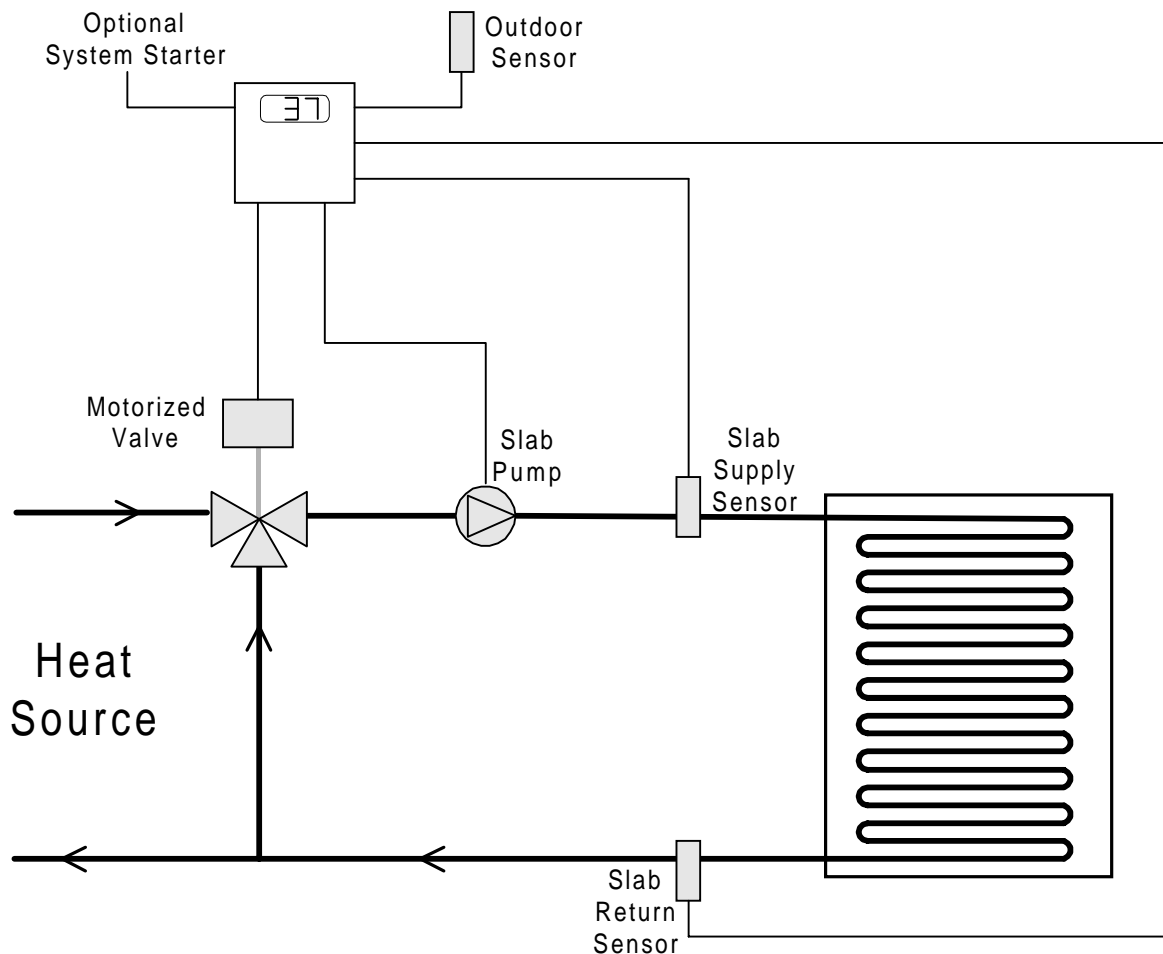

Wiring the Power

- Attach line voltage to the two orange wires extending from the back of the RSM.
- Use wire nuts, or wrap the connections with electrical tape.
- Class 1 voltages must enter the 1900 box through a different opening from any Class 2 wiring.

Wiring the Sensors

- The sensor wires have no polarity. Either wire from a sensor can be connected to the appropriately marked RSM screw terminal (see below) or the sensor common marked *COM*.
- Either or both screw terminals marked *COM* can be used as the sensor common. They are interchangeable.
- The two wires from the Outdoor sensor must be connected to the RSM front screws marked *OUT* and *COM*.
- The two wires from the Slab Supply sensor must be connected to the RSM front screws marked *SUP* and *COM*.
- The two wires from the Slab Return sensor must be connected to the RSM front screws marked *RTN* and *COM*.

Wiring the Output - Heat Source

- The RSM has one set of Normally Open (N.O.) dry contacts (blue wires) to activate the heat source for the slab.
- The N.O. contacts do not output power. They simply switch power through the circuit.
- If the heat source will be active whenever the RSM will activate the slab heat (as would be the case if the heat source is also used for space heating), connect the blue wires in series with the power for the slab pump.
- If the boiler for the slab heating system has a dedicated pump, simply connect the blue wires in series with the limit controls of the boiler so that both the boiler and pump start.
- If the boiler and pump for the slab must be energized separately, use the blue wires to energize an external double pole single throw (DPST) relay. Attach one set of external relay contacts in series with the slab pump power. Attach the other set of external relay contacts in series with the limit controls of the slab boiler.
- The RSM contacts can switch 10A, 1/8 HP at 120V. If the slab pump or boiler requires more power, an external relay must be used.

WIRING DIAGRAM

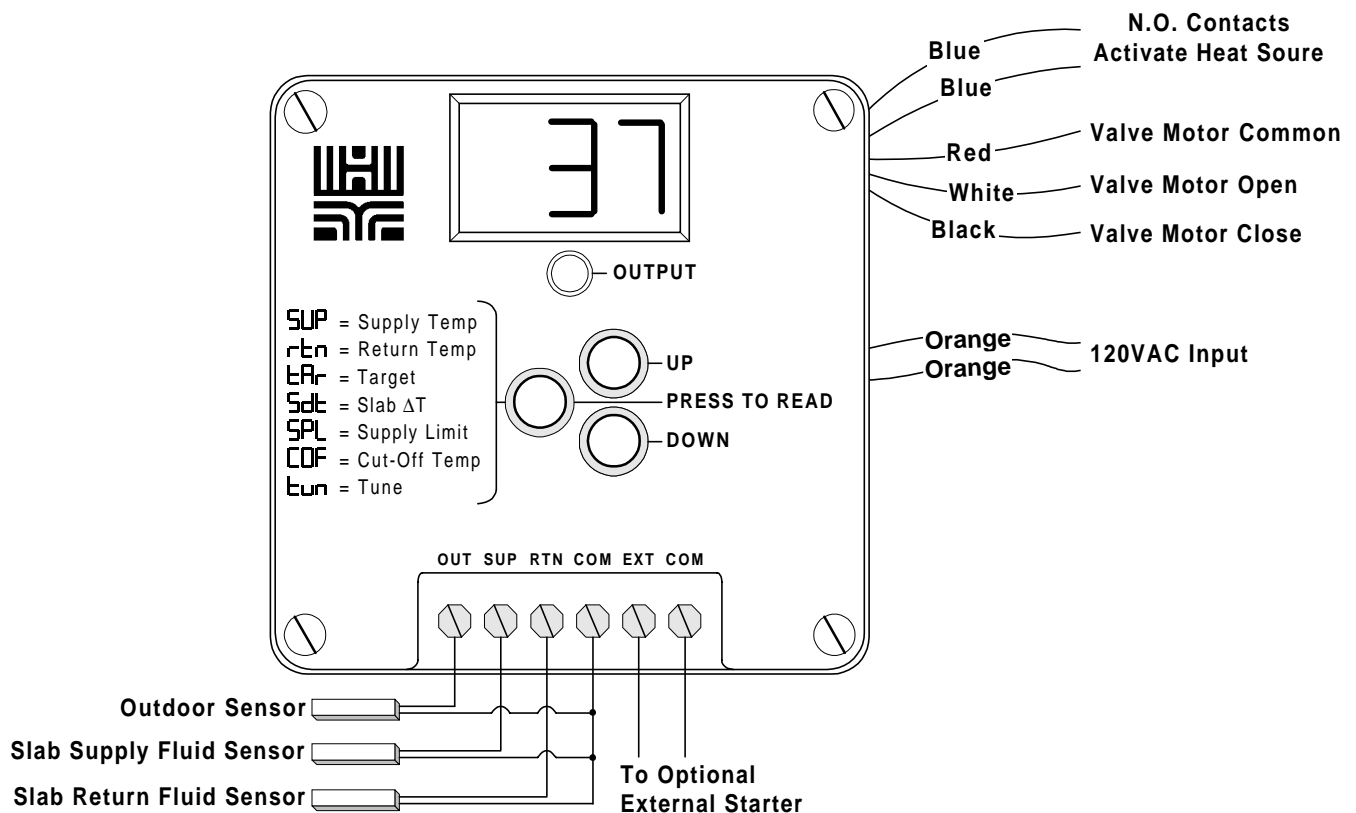

Wiring the Output - Valve Motor

- The valve outputs are dry contact only. They do not source any power to the valve motor.
- The RED wire is COMMON.
- The WHITE wire connects to OPEN (for more heat).
- The BLACK wire connects to CLOSE (for less heat).
- The wiring to Heat-Timer Radiant Valves (3-way HT#9285xx or 4-way HT#9284xx) is shown left. If using other valves, check the appropriate wiring with the valve manufacturer.

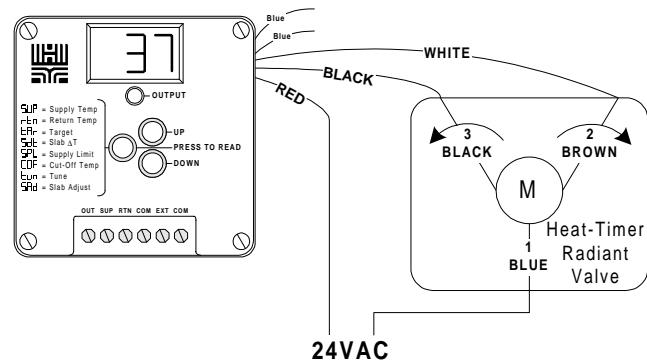

Wiring the Optional External System Starter

- The *EXT* and *COM* terminals may be used as an optional external system starter. The external starter signal must be a dry contact only. **If power is applied across the *EXT* and *COM* terminals, the RSM may be damaged.**
- A closure (short) across the terminals marked *EXT* and *COM* will cause the RSM to activate the slab heating system. The RSM will keep the system activated until the external starter signal is removed.
- To activate the slab heating system exclusively with the external starter, set the Outdoor Cutoff Temperature to OFF (see pg. 5).

Setting the Operating Mode

- The RSM can be field adjusted to display values either in °F or °C.
- The sensors input range is from -35 to 250°F or from -30 to 120°C.
- Do the following to set the desired range:
 1. Remove power to the RSM (if it was powered) and reapply power.
 2. The display will show the version number of the RSM software.
 3. Wait approximately 5 seconds and the display will change to read either °F or °C. If the display shows °F the RSM will operate in Fahrenheit degrees. If the display shows °C then the RSM will operate in Celsius degrees.
 4. If the desired range is shown, there is no need to proceed with the following steps.
 5. Hold down the *PRESS TO READ* button while pushing the *UP* or *DOWN* button to toggle between displays of °F or °C.
 6. When the correct range is shown, release the button and wait approximately 5 seconds. If any changes were made the display will flash. Then the RSM will display the outdoor air temperature.

Initial Settings

- After setting the operating mode, the RSM will display the outdoor air temperature. This is the default value for the RSM display.
- To see and/or adjust the other parameters, press then release the left button marked *PRESS TO READ*. The RSM will display a code to indicate which parameter will be displayed next. After two seconds, the value of the parameter will be shown.
- For those parameters where the values can be set (described pg. 5), press the *UP* or *DOWN* button to change the value while it is being displayed. Holding down the *UP* or *DOWN* button will cause the value to change more quickly.
- The *Slab Δ (delta) T* must be set to the slab design parameter for the maximum temperature differential between the slab supply and slab return temperatures (see pg. 6 for details).
- The *Supply Limit* must be set to the manufacturer's specification for the slab or the slab components. If high temperatures will damage the slab or the slab components, a separate limit controller should be installed (see pg. 6 for details).
- The *Outdoor Cutoff* comes factory set at 38°F. Therefore, the outdoor air temperature will need to fall below 38°F before the heating system will be activated (see pg. 6 for details).
- The *Tune* comes factory set at 0. This value will need to be adjusted when the heating system is running and there is precipitation (see pg. 6 for details).

DISPLAY SETTINGS and ADJUSTMENTS

PRESS LEFT BUTTON	RSM DISPLAY	Release center button to read value If value needs adjustment, press the UP or DOWN buttons To make large changes, keep the UP or DOWN button pressed
Once	SUP Supply Temp	This is the temperature of the fluid being supplied to the slab. If it does not read correctly, check the <i>Troubleshooting</i> guide.
Twice	rtn Return Temp	This is the temperature of the fluid returning from the slab. If it does not read correctly, check the <i>Troubleshooting</i> guide.
3 times	tAr Target	This is the target supply fluid temperature. The RSM controls the motorized valve to hold this target temperature. The target will change based on the sensor readings and the parameters set below.
4 times	Sdt Slab ΔT	The Slab Δ (Delta) T is determined by the design specifications for the particular slab. The Slab ΔT is the maximum difference between the Slab Supply and Slab Return temperature. The Slab ΔT can be adjusted from 5 to 50°F.
5 times	SPL Supply Limit	The Supply Limit is the highest temperature for which the slab heating system is rated. The manufacturer will specify the maximum temperature for their components. The Supply Limit can be adjusted from 70 to 180°F.
6 times	COF Outdoor Cutoff	The heating system will be activated when the outdoor temperature is below the Outdoor Cutoff. The Outdoor Cutoff temperature can be set to OFF, adjusted from 20°F to 50°F, or set to ON. In the OFF mode, the heating system can only be activated by the External Starter.
7 times	tun Tune	The Tune controls the temperature of the slab. The Tune should be set to the lowest value which still melts frozen precipitation. Do not adjust the Tune before the slab has had sufficient time to warm up.
8 times Default	Outdoor Temp	This is the temperature reading of the outdoor sensor. If it does not read correctly, check the <i>Troubleshooting</i> guide.

IMPORTANT: The values for *Slab Δ (delta) T*, *Supply Limit*, *Outdoor Cutoff*, and *Tune*, can only be changed when they are being displayed. Once the values have been set, they will remain in the RSM memory even if power to the unit is interrupted or lost.

WARNING: *The Slab Δ (delta) T and the Supply Limit must be set to the specification of the slab installer or component manufacturer. If these values are not set correctly, the slab may be permanently damaged. If high temperatures will damage the slab or the slab components, a separate high limit controller must be installed to shut down the heating system if excessively high temperatures are being supplied to the slab.*

OPERATION

Output Light

The output light has the following three indications:

Light Off

The heating system is not active. This will be the case when the outdoor temperature is above the *Outdoor Cutoff* temperature or when the *Outdoor Cutoff* is set to OFF and the External System Starter is not activated.

Light On

The heating source output is active. The blue output wires are continuous.

Flashing

The heating source output is active and the valve position is being corrected.

Setting the Slab ΔT

The *Slab $\Delta(\text{delta}) T$* is the temperature difference between the Slab Supply and the Slab Return which is necessary to melt frozen precipitation under extreme conditions. This maximum value is determined by the spacing and number of loops of tubing, and the slab type. The *Slab $\Delta(\text{delta}) T$* is actually a measurement of the maximum amount of energy which can be input to the slab at any time. To prevent slab damage, the *Slab $\Delta(\text{delta}) T$* must not be set higher than the design point. Follow the chart on pg. 5 to adjust the *Slab $\Delta(\text{delta}) T$* .

Setting the Supply Limit

The *Supply Limit* must be set according to the tubing and the slab manufacturer's specifications. If the *Supply Limit* is set too high, the slab could be permanently damaged. For example, if the slab consists of pavers laid in sand, the maximum slab supply temperature must be set below 140°F, since temperatures in excess of this may cause the sand to crystallize. Follow the chart on pg. 5 to adjust the *Supply Limit*.

Setting the Outdoor Cutoff

The *Outdoor Cutoff* is the temperature below which the slab heating source will be activated. When the outdoor temperature rises above this point, the slab heat source relay (blue wires) will be off. The *Outdoor Cutoff* is adjustable from 20°F to 60°F. The *Outdoor Cutoff* also has two special modes:

OFF

When the *Outdoor Cutoff* is set to *OFF*, the only way the heat source can be activated is to short out the two input terminals *EXT* and *COM* (see pg. 3). The heat source will stay active until the short is removed. This mode can be used to start the slab heating system with a switch.

ON

When the *Outdoor Cutoff* is set to *ON*, the slab heating system will be activated and run on its limits regardless of outdoor temperature. The RSM will control the valve to hold either the *Supply Limit* or *Slab $\Delta(\text{delta}) T$* whichever results in a lower Slab Supply temperature. This mode is useful for testing the RSM in warm weather.

CAUTION: If the RSM is left in the ON mode, excessive energy bills will result.

Follow the chart on pg. 5 to adjust the *Outdoor Cutoff*.

Setting the Tune

The *Tune* value provides an adjustment for the heat losses of a particular slab. Start with the factory default *Tune* setting of 0. Use the following steps to adjust the *Tune* value.

- When precipitation is expected, start the slab heating system and let it run at least 24 hours. This time is needed to allow the slab temperature to reach the melting point.
- When the precipitation begins, monitor the slab. Check if the precipitation is beginning to accumulate or if it is melted immediately.
- If there is accumulation, the slab temperature is too low. Increase the *Tune* value by one number (for example, from 0 to 1).
- If the precipitation is melting immediately, the slab may be using more energy than it needs. Decrease the *Tune* value by one number (for example, from 0 to -1).
- After making a change in the *Tune* value, wait at least four hours to see what affect this change will have on the slab.
- Repeat the above procedure as necessary until the lowest *Tune* value which still melts precipitation is determined.

Follow the chart on pg. 5 to adjust the *Tune*.

TROUBLESHOOTING

If there is no display: Check that the 120VAC power is connected to the two orange wires extending from the rear of the RSM. If power is present, try turning the RSM off and back on again.

If the display reads *OPN:** The RSM does not register an outdoor air temperature sensor is connected. Check that the wires from the outdoor sensor are connected to the front screw terminals marked *OUT* and *COM* (see pg. 3). If the wires are connected properly, they may be broken between the controller and the sensor. If the wires are continuous, see *Checking the Sensors*.

If the display reads *SHT:** The RSM registers a direct short across the outdoor air temperature sensor. Detach the outdoor sensor wire from the *OUT* terminal (see pg. 3). The display should change to read *OPN*. If it does not, the RSM may be damaged. If the display does change, check that the wires to the sensor are not shorted together. If the wires are fine, see *Checking the Sensors*.

If the display flashes *SUP:** The RSM registers a faulty Slab Supply sensor. After *SUP* the display should flash either *OPN* or *SHT*. *OPN* indicates the RSM does not register a Slab Supply sensor is connected. Check that the wires from the Slab Supply sensor are attached to the RSM's terminals *SUP* and *COM* (see pg. 3). Also check the wires have not been broken or damaged. *SHT* indicates a short across the Slab Supply sensor. Check the wires have not been shorted together. Finally, go to the section *Checking the Sensors* next page.

If the display flashes *RTN:** The RSM registers a faulty Slab Return sensor. After *RET* the display should flash either *OPN* or *SHT*. *OPN* indicates the RSM does not register a Slab Return sensor is connected. Check that the wires from the Slab Return sensor are attached to the RSM's terminals *RET* and *COM* (see pg. 3). Also check the wires have not been broken or damaged. *SHT* indicates a short across the Slab Return sensor. Check the wires have not been shorted together. Finally, go to the section *Checking the Sensors* pg 8.

* **CAUTION:** If any of the sensors are reading *OPN* or *SHT*, the RSM will shut down the slab heating system.

If the RSM does not activate the heating system: Remove any connections to the Blue output wires. Then take a wire and short out the two RSM terminals marked *EXT* and *COM* (see pg. 3). The red output light should turn on, and the Blue output wires should be continuous. If the Blue wires are not continuous, the RSM may be damaged. If the wires are continuous, reconnect the Blue output wires. If the system does not start, the problem is not with the RSM; check that your heating system is powered and has not been damaged. Finally, if the heating system does start, remove the jumper between *EXT* and *COM* and check that the outdoor air temperature displays below the *Outdoor Cutoff* temperature (see pg. 5). If it does not, the RSM will not activate the system. If the RSM is not reading the correct outdoor temperature, go to *Checking the Sensors*.

If the RSM does not operate the motorized valve: Check the *Target* temperature (see pg. 5). If the RSM is not heating, the display will read *OFF*. This would happen when the outdoor temperature is above the *Outdoor Cutoff* or the *Outdoor Cutoff* is set to *OFF*. If the *Target* temperature is lower than the Slab Supply temperature, then the valve should be closed**. If the *Target* temperature is above the Slab Supply temperature, then the motorized valve should move towards the open position**. If it does not, remove the three connections to the valve motor. When the RSM's red light flashes the RED and WHITE output wires should be register continuity (the continuity will only last for several seconds but should occur at least every 30 seconds.) If no continuity is registered, the RSM may be damaged. Otherwise, check the wiring to the valve (see pg. 4) and the valve itself.

** The valve motor is moved in small increments which may not immediately be noticeable. It may take 20 minutes or more for the valve to fully open or close.

If snow does not melt or slush is on the slab: Check the values on the Display chart (pg. 5) to make sure all the parameters are set correctly. If the slab heating system has not been active for at least 24 hours, the slab may not have gotten up to temperature and the RSM will be controlling to hold the *Slab Δ (delta) T* or the *Supply Limit* whichever results in a lower Slab Supply temperature. If the motorized valve is in the fully open position, the heating system can not provide enough heat to melt the precipitation. If none of the above are a problem, then adjust the *Tune* (see pg. 6).

Checking the sensors

Each of the three RSM sensors are interchangeable and can be tested in the same way. The display (see pg. 7) will indicate which sensor is registering open or short, or the temperature reading for that sensor. To test the sensor, remove the pair of sensor wires connected to the RSM terminals. Take a resistance reading across the detached wires going to the sensor. If the reading shows:

OPEN or a resistance greater than 100,000Ω: Check the wires going to the sensor. They may have been broken or become disconnected. If the wires are fine, check the resistance at the sensor itself. If the value is still open, the sensor has been damaged and needs to be replaced.

SHORT or a resistance less than 100Ω: Check the wires going to the sensor. They may have become shorted together in the run of the wire. If not, check the resistance at the sensor itself. If there still is no resistance, the sensor has been damaged and needs to be replaced.

Resistances from 200Ω to 100,000Ω: Find the temperature that corresponds to the resistance value on the chart. If the sensor appears to be outputting correctly, check that the wires were properly connected to the RSM. If they were, the RSM may have been damaged. If the sensor is not outputting correctly, take another reading at the sensor itself. If this is correct, the problem is in the wiring between the sensor and the RSM. Otherwise, the sensor has been damaged, and should be replaced.

TEMPERATURE (in degrees F)	VALUE (in Ohms)
0	42683
10	31215
20	23089
25	19939
30	17264
35	14985
40	13040
45	11374
50	9944
55	8714
60	7653
70	5941
80	4649
90	3667
100	2914
110	2332
120	1879
130	1524
140	1243
150	1021
160	842
170	699
180	583
190	489
200	412

For Technical Support or
Additional Product Information Contact:

Heat-Timer Corporation
20 New Dutch Lane
Fairfield, NJ 07004

Phone (973) 575-4004 Fax (973) 575 -4052

HT #059204
Rev A