

INSTALLATION/OPERATING INSTRUCTIONS

DIGI-SPAN[®]

SPC HI TEMP

Digital Set Point Control

Temperature Range 250 to 950°F (120 to 520°C)

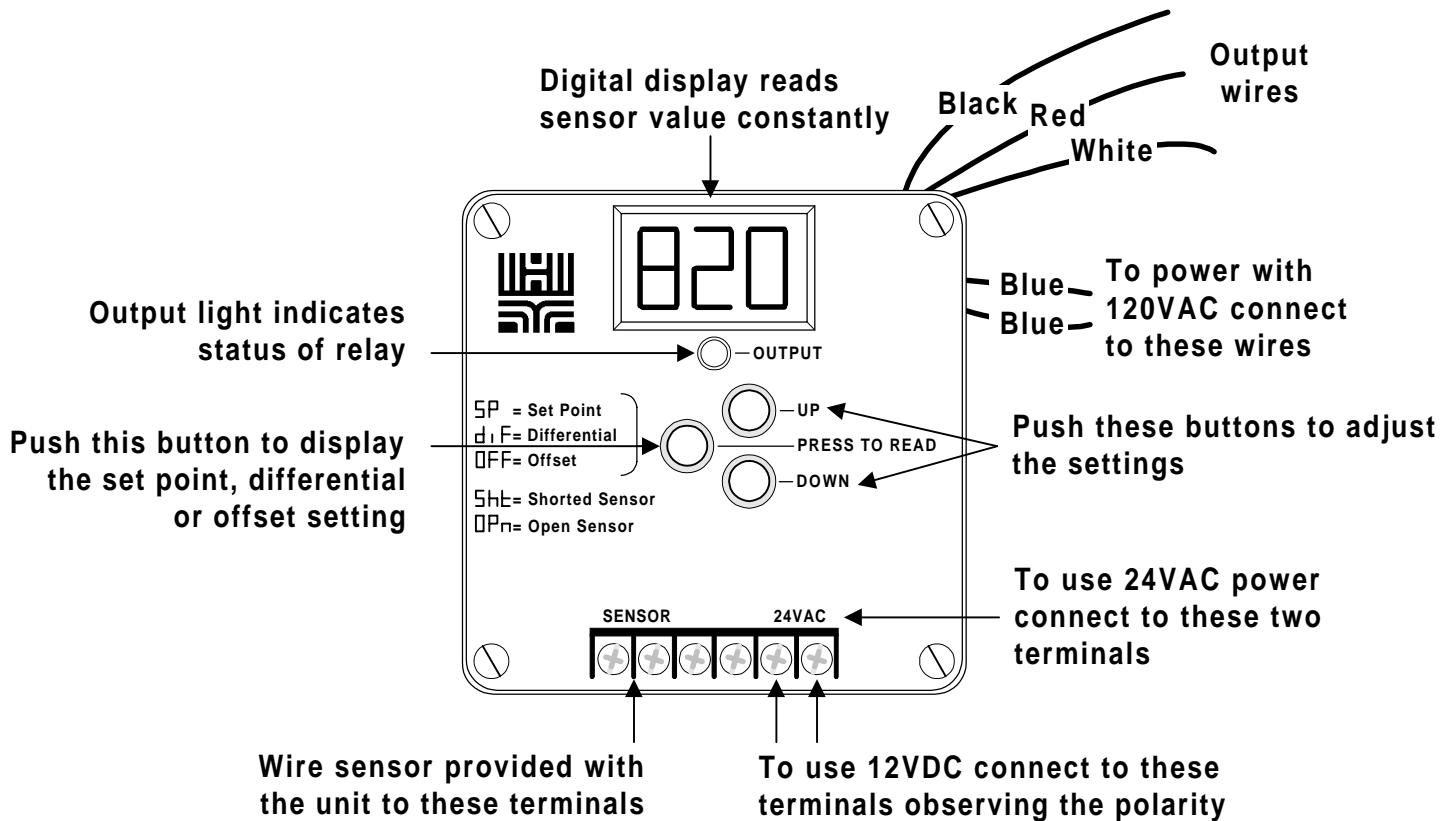

Warning: This Heat-Timer[®] control is strictly an operating control; it should never be used as a primary limit or safety control. All equipment must have its own certified limit and safety controls required by local codes. The installer must verify proper operation and correct any safety problems prior to the installation of this Heat-Timer control.

LIMITED ONE YEAR WARRANTY

This Heat-Timer device was thoroughly tested for defects and workmanship before leaving our factory. We do warrant the equipment to be free of defects under normal use for a period of one year from the date of installation. Transportation charges for factory repairs must be prepaid. Damage to the Heat-Timer device or any of its components due to misuse, abuse, improper installation, or caused by power failures, fire, flood, or lightning are not covered by this warranty. The company assumes no liability for indirect or consequential damages of any nature. This Heat-Timer warranty applies only to the original purchaser/user, is not assignable or transferable, and does not cover damage to the device occurring in shipment. Any service, repairs, modifications or alterations to the unit not expressly authorized by the company will invalidate the warranty. This warranty is in lieu of all other warranties expressed or implied.

INSTALLATION

Mounting the Controller

- The SPC is designed to mount on a 1900 (4"x4") electrical box.
- If the SPC is to be panel mounted, or if additional room is needed for wiring, an extension skirt is available*.
- Locate the SPC in a convenient location near the unit to be controlled.
- Mount the unit away from excessive heat or cold. Ambient operating temperature is from 20 to 120°F.
- After completing all the wiring connections (see below) use the two screws provided to mount the SPC to the 1900 box.

Installing the Temperature Sensor

- The sensor is provided with high temperature wire. This wire should not be cut.
- After running the high temperature wire to a lower temperature area, the wire can be extended up to 500' with 18 gauge shielded wire. The temperature of the area where the splice is performed can not exceed the temperature rating of the extending wire.
- Do not run wires in conduit with line voltage.
- The SPC will operate based on the temperature it reads at the sensor location. Therefore, select a sensor location which is representative of the entire system.

Wiring the Sensor

- The sensor wires can be connected to the two screws on the front of the SPC marked *SENSOR*.
- The wires can also be connected to the rear of the SPC using the Rear Wire connector*. Connect the sensor wires to the orange and yellow wires from the Rear Wire connector.
- Polarity is not important. Either wire from the sensor can be connected to either SPC sensor input.

Wiring the Power - SPC can use either 120VAC, 24VAC, or 12VDC

120VAC

- Attach line voltage to the two blue wires extending from the back of the SPC.
- Use wire nuts, or wrap the connections with electrical tape.
- Class 1 voltages must enter the enclosure through a different opening from any Class 2 wiring.

24VAC

- Use a dedicated transformer with at least a 5VA output.
- Bring 24VAC to the two screws on the front of the SPC marked *24VAC*.
- 24VAC can also be connected to the rear of the SPC using the Rear Wire connector*. Connect the 24VAC to the violet and gray wires from the Rear Wire connector.

12VDC

- The polarity of the connection is important. If the polarity is reversed, the SPC will not be damaged. However, it will not operate unless the polarity is corrected.
- Bring the (+) side of the 12VDC to the inner screw marked *24VAC* (see front page). Bring the (-) side of the 12VDC to the outer screw marked *24VAC*.
- 12VDC can also be connected to the rear of the SPC using the Rear Wire connector*. The (+) side of the 12VDC must be connected to the connector's violet wire. The (-) side of the 12VDC must be connected to the connector's gray wire.

* The Optional Mounting Kit includes the extension skirt, the Rear Wire connector, and an input terminal cover. Order separately as HT #908520.

WARNING

The SPC can accept only one source of power: 120VAC, 24VAC, or 12VDC. If more than one power source is applied, the unit may be damaged.

TYPICAL WIRING DIAGRAM

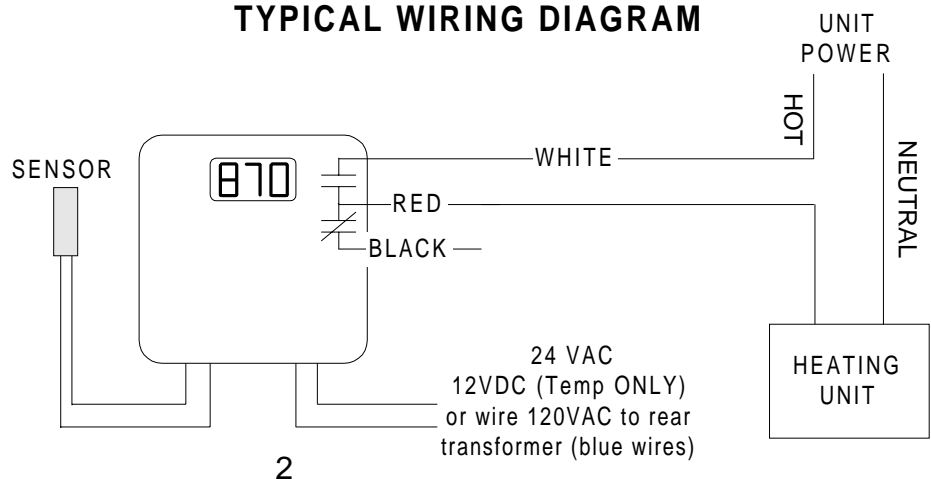

Wiring the Output

- The SPC has a SPDT (single pole double throw) relay output rated at 10A, 1/8 HP.
- The outputs are dry contacts only. They do not source any power.
- The Red wire is the relay Common.
- The White wire is the N.O. (normally open) relay contact.
- The Black wire is the N.C. (normally closed) relay contact.
- If the output is carrying any Class 1 voltages, then it must enter the enclosure through a different opening from any Class 2 wiring.

Setting the Operating Modes (°F or °C, Heating or Cooling)

- The operating modes can be set when the SPC is powered up. Once the operating modes have been set, they need not be set again (unless the SPC is changed to a different application). Power outages will not cause the modes to be reset.
- Note that if you do change the mode of operation, you will need to reset the set point, differential and offset.
- To set the operating modes, use the following steps:
 1. Remove power to the SPC (if it was powered) and reapply power.
 2. The display will show the software version number.
 3. Wait approximately 5 seconds and the display will change to read either °F or °C. If the display shows °F then the SPC will operate in Fahrenheit degrees. If the display shows °C then the SPC will operate in Celsius degrees.
 4. If the desired mode is displayed, move on to step 6.
 5. Hold down the center button while pushing either the *UP* or *DOWN* button to toggle between the displays of °F and °C.
 6. When the correct temperature mode is selected, release the buttons and wait approximately 5 seconds.
 7. The display will change to read either *H* or *C*. If the display shows *H* then the SPC will be in a heating mode. The relay will close and the red output light will be on when the temperature is below the set point. If the display shows *C* then the SPC will be in a cooling mode. The relay will close and the light will be on when the temperature is above the set point.
 8. If the desired mode is displayed, move on to step 10.
 9. Hold down the center button while pushing either the *UP* or *DOWN* button to toggle between the displays of *H* and *C*.
 10. When the correct heating or cooling mode is selected, release the buttons and wait approximately 5 seconds. If any changes were made to the operating modes, the display will flash. Then the SPC will display the sensor temperature.

OPERATION

SET POINT and DIFFERENTIAL EXAMPLE

Set Point **350°F**
Differential **20°F**

Heating Mode

On a drop in Temp to **330°F** Relay Energizes
Output light is **ON**

On a rise in Temp to **350°F** Relay Deenergizes
Output light is **OFF**

Cooling Mode

On a rise in Temp to **350°F** Relay Energizes
Output light is **ON**

On a fall in Temp to **330°F** Relay Deenergizes
Output light is **OFF**

NOTE: If System Temp is between 331°F and 349°F the output may be on or off depending on whether the system temp is rising or falling

Adjusting the Set Point

- The set point is the temperature the SPC will use to control the system.
- When the sensor temperature reaches the set point, the relay will energize (or de-energize depending on the operating mode and differential as shown above).
- To adjust the set point, use the following steps:
 1. SPC should be displaying sensor temperature.
 2. Press the center button and release it. The display will change to show *SP*. Wait 2 seconds or press the *UP* or *DOWN* button and the set point will be displayed.
 3. Press and hold either the *UP* or *DOWN* button until the desired set point is displayed.
 4. Wait approximately 10 seconds. If the set point was changed, the display will flash. Then the SPC will return to display-

ing the sensor temperature. (If you don't want to wait, press the center button once for the differential, twice for the offset, or three times to immediately display the sensor temperature).

Adjusting the Differential

- The differential controls how many degrees the system can fluctuate around the set point. It is used to prevent short cycling of the unit being controlled (see example previous page).
- To set the differential, use the following steps:
 1. SPC should be displaying sensor temperature.
 2. Press and release the center button twice. The display will change to show *dIF*. Wait 2 seconds or press the *UP* or *DOWN* button and the differential will be displayed.
 3. Press and hold either the *UP* or *DOWN* button until the desired differential is displayed.
 4. Wait approximately 10 seconds. If the differential was changed, the display will flash. Then the SPC will return to displaying the sensor temperature. (If you don't want to wait, press the center button once for the offset or twice to immediately display the sensor temperature.)

Adjusting the Offset

- The offset value adjusts the sensor reading. It allows you to calibrate the sensor by the number of degrees selected.
- To adjust the offset, use the following steps:
 1. SPC should be displaying sensor temperature.
 2. Press the center button three times and release it. The display will change to show *OFF*. Wait 2 seconds or press the *UP* or *DOWN* button and the offset will be displayed.
 3. Press and hold either the *UP* or *DOWN* button until the desired offset is displayed.
 4. Wait approximately 10 seconds. If the offset was changed, the display will flash and then show the corrected sensor reading. (If you don't want to wait, press the center button once.)

TROUBLESHOOTING

No Display: Check the power to the SPC. The SPC can run off any of the power sources described on page 2. Turn the power off and back on.

OPN Display: The SPC does not see a sensor connected. Check the wires from the sensor are continuous from the sensor to the SPC controller. Then follow the procedure for Incorrect Temperature Display.

Below Range Temperature Display: The SPC sees a low resistance across the input terminals. This may be because the sensor temperature is below 250°F or because the sensor is shorted. If you remove the sensor wires from the SPC terminals, the display should change to read *OPN*. If the display does not change to *OPN*, the SPC may be damaged.

Incorrect Temperature Display: Remove the wires from the *SENSOR* screws. The display should change to read *OPN*. If it doesn't, the SPC may be damaged. Take an ohm reading across the detached sensor wires. The ohm reading should correspond to the chart on the right. If the ohm reading is significantly different, the sensor may be damaged.

Output does not activate at the desired temperature: Check the set point and differential values. In a heating application, the red light will not come on until the temperature drops below the set point minus the differential. In a cooling application, the red light will not turn off until the temperature drops below the set point minus the differential.

SPC does not activate the output: First remove all connections to the Red, White, and Black output wires. If the Output Red Light is on, the relay should be energized; the Red to White wires should be continuous, and the Red to Black wires should be open. If the Output Red Light is off, the relay should be de-energized; the Red to White wires should be open, and the Red to Black wires should be continuous. If the above two conditions are met, the SPC is working normally. Check the unit the SPC is controlling.

TEMPERATURE (in degrees F)	VALUE (in Ohms)
250	1464
275	1517
300	1569
325	1622
350	1674
375	1725
400	1773
425	1824
450	1875
475	1926
500	1977
525	2027
550	2077
575	2127
600	2174
625	2222
650	2272
675	2321
700	2370
725	2419
750	2464
800	2559
850	2655
900	2749
950	2842



20 New Dutch Lane, Fairfield, NJ 07004
973-575-4004 • FAX 973-575-4052

<http://www.heat-timer.com>

HT 059226-00 REV B