

INSTALLATION/OPERATING INSTRUCTIONS

DIGI-SPAN[®]

MCF TEMP

Modulating Digital Set Point Control
Temperature Range -30 to 250°F (-35 to 120°C)

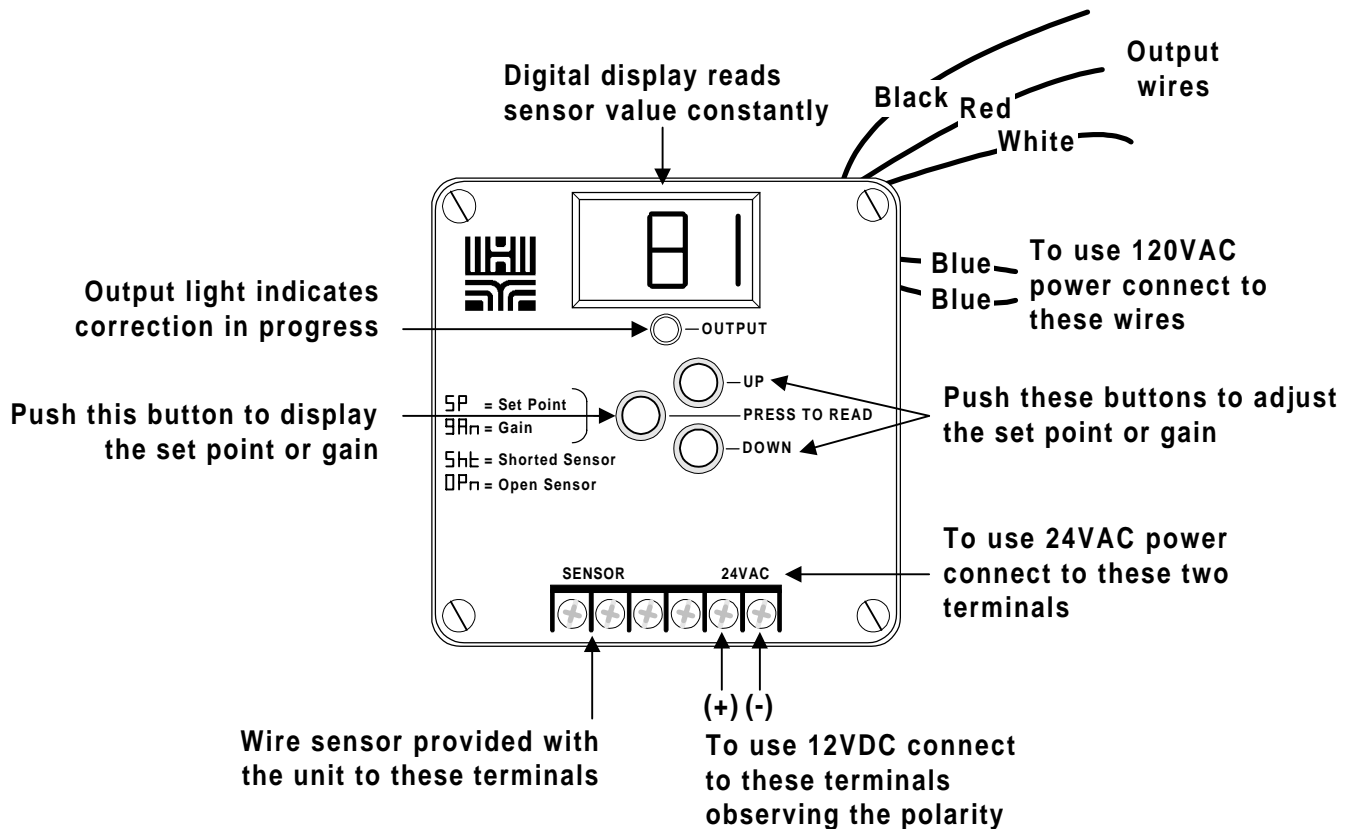

Warning: This Heat-Timer[®] control is strictly an operating control; it should never be used as a primary limit or safety control. All equipment must have its own certified limit and safety controls required by local codes. The installer must verify proper operation and correct any safety problems prior to the installation of this Heat-Timer control.

LIMITED ONE YEAR WARRANTY

This Heat-Timer device was thoroughly tested for defects and workmanship before leaving our factory. We do warrant the equipment to be free of defects under normal use for a period of one year from the date of installation. Transportation charges for factory repairs must be prepaid. Damage to the Heat-Timer device or any of its components due to misuse, abuse, improper installation, or caused by power failures, fire, flood, or lightning are not covered by this warranty. The company assumes no liability for indirect or consequential damages of any nature. This Heat-Timer warranty applies only to the original purchaser/user, is not assignable or transferable, and does not cover damage to the device occurring in shipment. Any service, repairs, modifications or alterations to the unit not expressly authorized by the company will invalidate the warranty. This warranty is in lieu of all other warranties expressed or implied.

INSTALLATION

Mounting the Controller

- The MCF is designed to mount on a 1900 (4"x4") electrical box.
- If the MCF is to be panel mounted, or if additional room is needed for wiring, an extension skirt is available*.
- Locate the MCF in a convenient location near the unit to be controlled.
- Mount the MCF away from excessive heat or cold. Ambient operating temperature is from 20 to 120°F.
- After completing all the wiring connections (see below) use the two screws provided to mount the MCF to the 1900 box.

Installing the Temperature Sensor

- The temperature sensor wires can be extended up to 500' by splicing with 18 gauge shielded wire.
- Do not run wires in conduit with line voltage.
- If measuring liquid temperature, the sensor should be inserted into a 3/8" ID well (HT#904011 or equivalent).
- The MCF will operate based on the temperature it reads at the sensor location. Therefore, select a sensor location which is representative of the entire system.

Wiring the Sensor

- The sensor wires can be connected to the two screws on the front of the MCF marked *SENSOR*.
- The wires can also be connected to the rear of the MCF using the Rear Wire connector*. Connect the sensor wires to the orange and yellow Rear Wires.
- Polarity is not important. Either wire from the sensor can be connected to either MCF sensor input.

Wiring the Power - MCF can use either 120VAC, 24VAC, or 12VDC

120VAC

- Attach line voltage to the two blue wires extending from the back of the MCF.
- Use wire nuts, or wrap the connections with electrical tape.
- Class 1 voltages must enter the enclosure through a different opening from any Class 2 wiring.

24VAC

- Use a dedicated transformer with at least a 5VA output.
- Bring 24VAC to the two screws on the front of the MCF marked *24VAC*.
- 24VAC can also be connected to the rear of the MCF using the Rear Wiring connector*. Connect the 24VAC to the violet and gray Rear Wires.

12VDC

- The polarity of the connection is important. If the polarity is reversed, the MCF will not be damaged. However, it will not operate unless the polarity is corrected.
- Bring the (+) side of the 12VDC to the inner screw marked *24VAC* (see front page). Bring the (-) side of the 12VDC to the outer screw marked *24VAC*.
- 12VDC can also be connected to the rear of the MCF using the Rear Wiring connector*. The (+) side of the 12VDC must be connected to the violet Rear Wire. The (-) side of the 12VDC must be connected to the gray Rear Wire.

WARNING

The MCF can accept only one source of power: 120VAC, 24VAC, or 12VDC. If more than one power source is applied, the unit may be damaged.

* The Optional Mounting Kit includes the extension skirt, the Rear Wire connector, and an input terminal cover. Order separately as HT #908520.

TYPICAL WIRING DIAGRAM

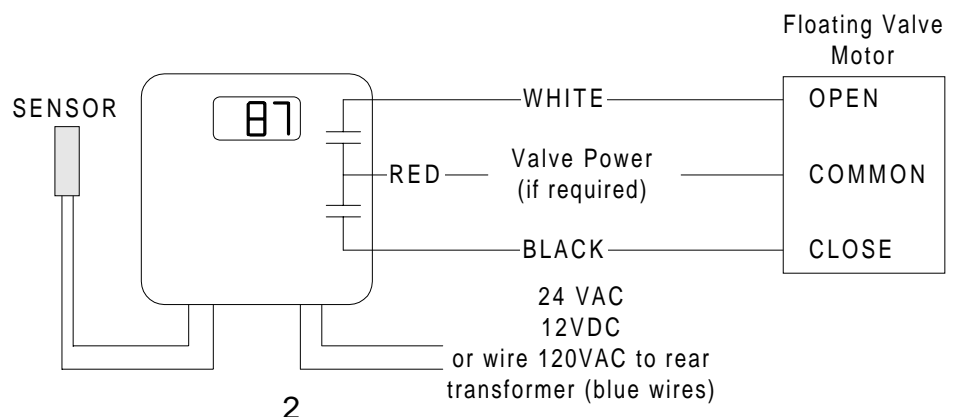

Wiring the Output

- The MCF has 2 SPST (single pole single throw) relays output rated at 10A, 1/8 HP.
- The outputs are dry contacts only. They do not source any power.
- The Red wire is Common. If the valve has only three wires, it is necessary to wire in a power source for the valve. One side of the valve power source is connected to the valve Common, and the other side is connected to the MCF Red wire Common (see diagram opposite page). Check wiring instructions for the specific valve before making any connections.
- The White wire connects to the valve Open.
- The Black wire connects to the valve Close.

Setting the Temperature Display Mode

- Whenever the MCF is powered up, it will display the software version number and then the temperature display mode. If the mode is correct, there is no need to make any adjustments.
- Once the mode is set for a particular application, it will be retained in memory and will not need to be reset.
- Note that if you do change the mode of operation, you will need to reset the set point and gain.
- To set the temperature display mode, use the following steps:
 1. Remove power to the MCF (if it was powered) and reapply power.
 2. The display will show the software version number.
 3. Wait approximately 5 seconds and the display will change to read either °F or °C. If the display shows °F then the MCF will operate in Fahrenheit degrees. If the display shows °C then the MCF will operate in Celsius degrees.
 4. If the desired mode is displayed, move on to step 6.
 5. Hold down the center button while pushing either the *UP* or *DOWN* button to toggle between the displays of °F and °C.
 6. When the correct temperature mode is selected, release the buttons and wait approximately 5 seconds. The display will flash and then show sensor temperature.

OPERATION

Adjusting the Set Point

- The MCF will control the modulation of the motorized valve to maintain an average temperature equal to the set point.
- To adjust the set point, use the following steps:
 1. The MCF should be displaying sensor temperature.
 2. Press the center button and release it. The display will change to show *SP*. Wait 2 seconds or press the *UP* or *DOWN* button and the set point will be displayed.
 3. Press and hold either the *UP* or *DOWN* button until the desired set point is displayed.
 4. Wait approximately 10 seconds. If the set point was changed, the display will flash. Then the MCF will return to displaying the sensor temperature. (If you don't want to wait 10 seconds, press the center button once to adjust the gain or twice to immediately display the sensor temperature).

Adjusting the Gain

- The gain controls how aggressively the valve will move based on set point and changes in the system temperature.
- A higher gain setting will result in larger valve movements than a lower gain setting. Zero is a neutral gain setting. Positive gain settings generate a larger valve movement than negative settings given the same change in system temperature.
- On initial startup, use a gain setting of zero. Don't adjust the gain until the system is fully warmed up. It is best to adjust the gain under average load conditions. If the gain is adjusted when there is little or no load, it may not be set correctly.
- If the system temperature tends to stay below the set point, increase the gain. If the system temperature overshoots and undershoots the set point rapidly, decrease the gain.
- Once the gain has been set for a particular system, it should not need to be readjusted.
- To set the gain, use the following steps:
 1. The MCF should be displaying sensor temperature.
 2. Press and release the center button twice. The display will change to show *GAn*. Wait 2 seconds or press the *UP* or *DOWN* button and the gain will be displayed.
 3. Press either the *UP* or *DOWN* button to change the gain.
 4. The gain should not normally be increased or decreased more than a couple numbers at any given time. After a change in the gain setting, wait at least 15 minutes to evaluate the effect the change has on the system before making another change.
 5. After releasing the buttons, wait approximately 10 seconds. If the gain was changed, the display will flash and then show sensor temperature. (If you don't want to wait, press the center button once).

Output Light

- The output light will flash whenever the MCF is adjusting the valve position.
- The length of the flash will vary from 1/2 a second to 4 seconds. The time between flashes can vary from 5 seconds to 30 seconds or even longer if the set point is satisfied.
- The MCF never drives the valve open or closed for more than 4 seconds. Instead, it makes a change and then evaluates the effect of that change on the system.

TROUBLESHOOTING

No Display: Check the power to the MCF. The MCF run on any of the power sources described on page 2. Turn the power off and back on.

OPN Display: The MCF does not see a sensor connected. Check the wires are continuous from the sensor to the MCF controller. Then follow the procedure for Incorrect Temperature Display.

SHT Display: The MCF sees a short across the input terminals. If you remove the sensor wires from the MCF terminals, the display should change to read *OPN*. If the display does not change to *OPN*, the MCF may be damaged.

Incorrect Temperature Display: Remove the wires from the *SENSOR* screws. The display should change to read *OPN*. If it doesn't, the MCF may be damaged. Take an ohm reading across the detached sensor wires. The ohm reading should correspond to the chart on the right. If the ohm reading is significantly different, the sensor may be damaged.

OUTPUT Red Light does not stay on: The maximum length of the output pulse to the valve motor (and therefore the maximum length of the red light flash) is 4 seconds.

MCF does not move the motor: First check the valve wiring. The MCF does not output 24VAC directly to the valve motor. Instead, the valve power must be wired as shown on page 2. Next remove any wires connected to the Red, White, and Black output wires. When the *OUTPUT* light flashes check for continuity first across the Red to White wires, and then across the Red to Black wires. If during the flash there is continuity across the Red to White wires, the MCF is sending an appropriate signal to open the valve motor. If during the flash there is continuity across the Red to Black wires, the MCF is sending an appropriate signal to close the valve motor. If there is continuity across either pair of wires when the light is not on, the MCF may be damaged. Also, if neither pair of wires are continuous when the light is on, the MCF may be damaged.

MCF does not control system to hold the set point temperature: The set point is the average temperature the system will hold. If the system temperature significantly overshoots and undershoots the set point, decrease the gain setting by one or two. If the system temperature is almost always below the set point, increase the gain setting by one or two. Wait approximately 15 minutes to see how the system responds.

TEMPERATURE (in degrees F)	VALUE (in Ohms)
-10	59075
0	42683
10	31215
20	23089
30	17264
40	13040
50	9944
60	7653
70	5941
80	4649
90	3667
100	2914
110	2332
120	1879
130	1524
140	1243
150	1021
160	842
170	699
180	583
190	489
200	412
210	349
220	297
230	253

Heat-Timer Corporation
20 New Dutch Lane
Fairfield, NJ 07004
Phone (973) 575-4004
Fax (973) 575 -4052

<http://www.heat-timer.com>
HT 059208 REV A