

# HEAT-TIMER<sup>®</sup>

## INSTALLATION AND OPERATION INSTRUCTIONS

# 4-20mA EMS Interface

## Adds 4-20mA Set point capability to Mini-MOD and SQ-Elite Series Controls

The 4-20mA EMS Interface provides the Mini-MOD and SQ-Elite series controls with the capability of receiving an external Set Point as a 4-20mA signal through an Energy Management or Building Management Systems (EMS/BMS). The External Set Point can be either temperature or Pressure depending on the control and its settings. In addition, the Mini-MOD and the SQ-Elite controls can be shutdown by the EMS/BMS system.

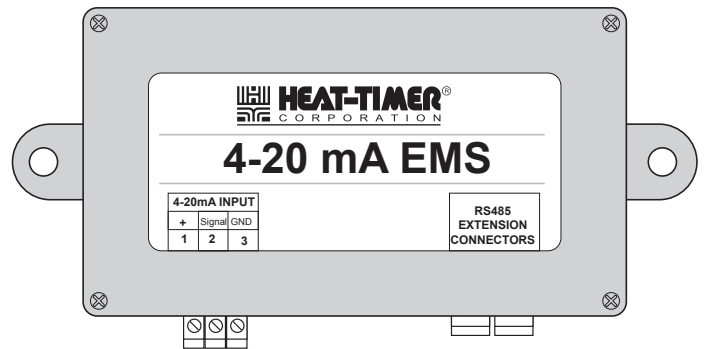

## WIRING

### Wiring the EMS Signal

- The signal must be a two-wire 4-20mA.
- A system sensor must be installed to the Mini-MOD or SQ-Elite control.
- The External Set Point must be set up correctly (See Mini-MOD and SQ-Elite documentation). These settings will allow the Mini-MOD and SQ-Elite to read and monitor the system temperature and also monitor the 4-20mA input to remotely adjust the set point to the desired value.
- The 4-20mA EMS Interface can source the current for the 4-20mA input signal. It provides an excitation DC current. If using the 4-20mA EMS Interface to source the power, attach the (+) side of the EMS/BMS signal to the 4-20mA EMS Interface terminal marked +. Attach the (-) side of the EMS/BMS signal to the 4-20mA EMS Interface terminal marked SIGNAL.
- If the EMS/BMS or other equipment signal sources the current (provides the excitation voltage), attach the (+) side of the 4-20mA input to the 4-20mA EMS Interface terminal marked SIGNAL. Attach the (-) side of the 4-20mA input to the 4-20mA EMS Interface terminal marked GND.

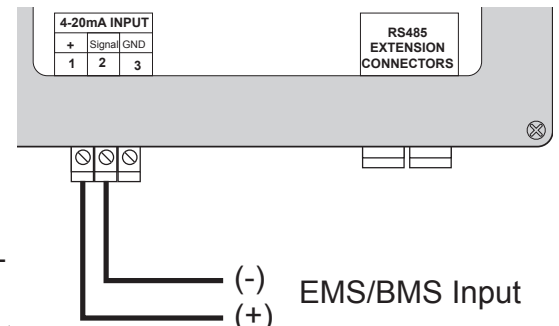

### 4-20 mA EMS Interface Sources DC Excitation Voltage

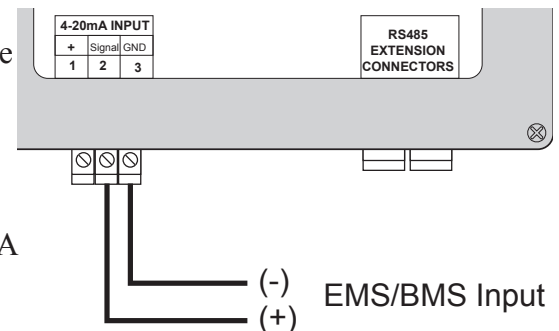

### EMS/BMS Sources Excitation Voltage

**⚠ WARNING**

The 4-20mA EMS interface can either source DC current or accept DC current from an EMS/BMS System. Each configuration has a different wiring schematic. Wiring the current to the “+” and “Signal” terminals will damage the 4-20mA EMS interface.

**Connecting 4-20mA EMS Interface to Mini-MOD with Two Extension Panels using RS485**

**Mini-MOD**

**Mini-MOD Extension A**

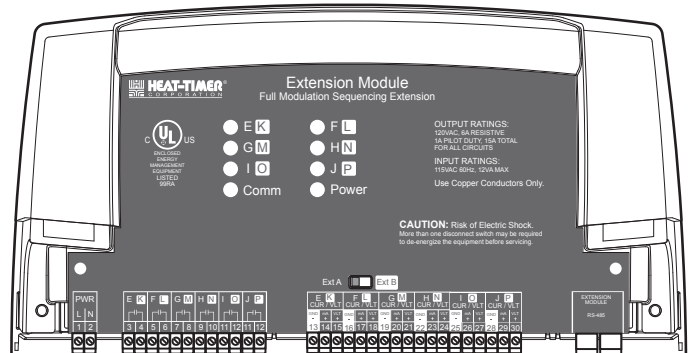
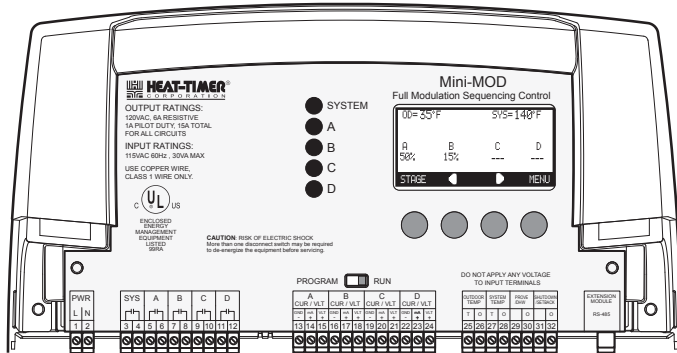

**4-20mA EMS Interface**

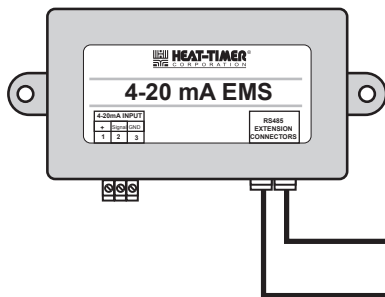

**Mini-MOD Extension B**

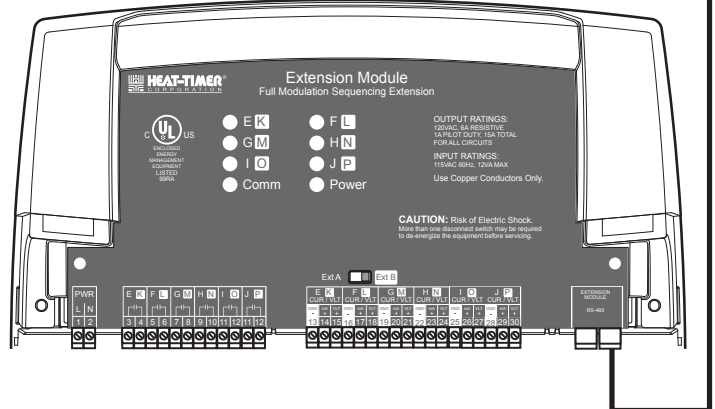

**Connecting the 4-20mA EMS interface to the Mini-MOD or SQ-Elite**

- The 4-20mA EMS Interface connects to the Mini-MOD or SQ-Elite using an RS485 (phone plug).
- When having to use the RS485 to connect to Extensions, use the extra RS485 (phone plug).
- The control, 4-20mA EMS Interface and two Extensions can be connected in series using the RS485.