

HEAT-TIMER[®]

INSTALLATION INSTRUCTIONS

3-IN-1 TEMPERATURE SENSOR

Immersion, Outdoor, and Strap-On Sensor Installation

The new Heat-Timer Sensor Enclosure can be used for Immersion, Outdoor, or Strap-On installations. The enclosure material is designed to tolerate temperatures up to 220°F/105°C as well as withstand outdoor weather conditions. The package comes complete with the Enclosure, Temperature Sensor, Strap-on Tie Wrap, and Outdoor Weather Sealing Label.

- The sensor wires can be extended up to 500' using a shielded 2-conductor 18 gauge cable (Belden #8760 or equivalent (#18/2)).
- DO NOT ground the shield at the sensor. Connect the Shield at the control using the sensor terminals marked with a "COM" or "O".
- Do not run sensor wires in conduit with line voltage wiring.

⚠ ALERT

DO NOT CONNECT the Shield at the sensor end. However, the shield must be connected at the control sensor terminal marked with "COM" or "O" with one of the other sensor wires.

Figure 1

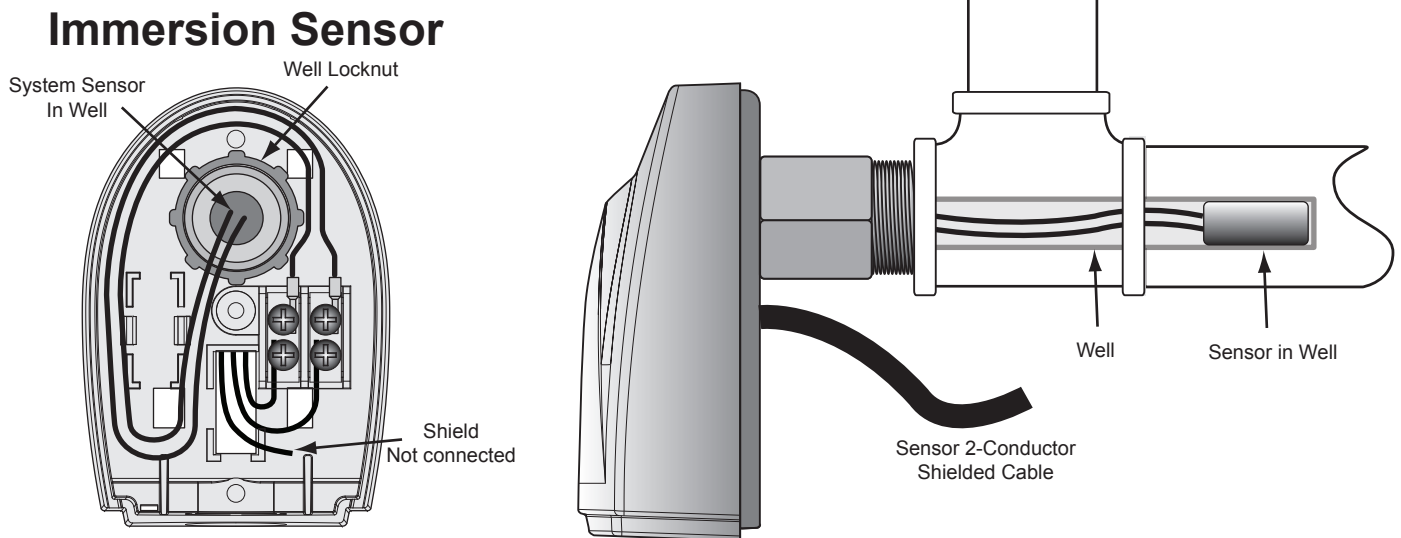

Immersion Sensor Installation

- The Immersion Sensor is designed to be installed in a well (Use NPT Well #904011-00 or equivalent).
- For accurate system temperature reading, place the sensor well approximately 10' feet past the last heating/cooling unit on the common supply header before any takeoffs.
- The well's threaded locknut should hold the Sensor Enclosure Base in place.
- Insert the sensor into the well and connect the sensor wires to the upper terminals as show in Figure 1.
- Snake the extension cable through any of the openings or knockouts and connect the wires to the lower terminals as shown in Figure
- Screw the Sensor Enclosure Cover to the Base.
- When the control is powered, check for sensor temperature reading.

Outdoor Sensor

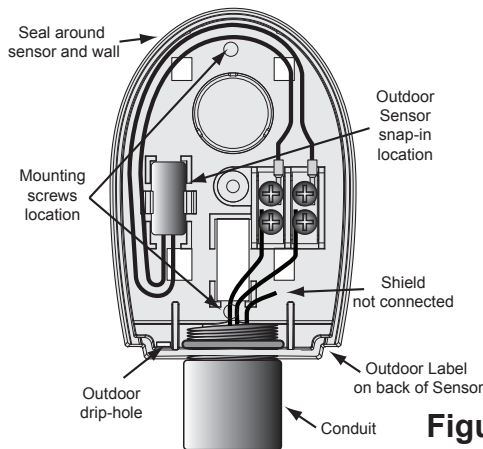

Figure 2

Strap-On Sensor

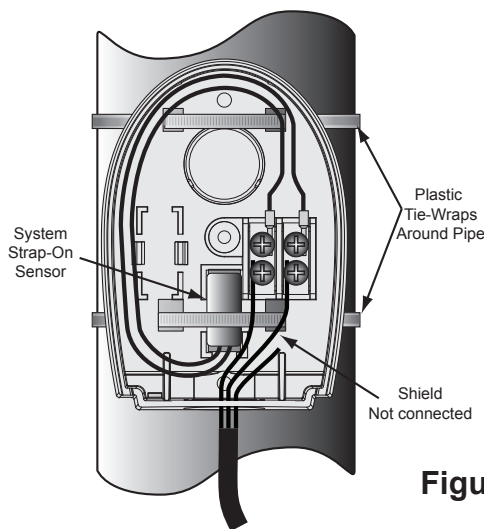

Figure 3

Outdoor Sensor Installation

- Locate the sensor in the shade on the north side of the building. The sensor should be away from doors, windows, exhaust fans, vents, or other possible heat sources and away from direct sunlight.
- The sensor should be mounted approximately 10' feet above ground and 4" from the building wall.
- Adhere the Outdoor Label provided to the back of the sensor base.
- Use the Enclosure Base bottom knockout for the conduit. Use the locknut to hold the conduit and enclosure base together.
- If screws are used to affix the enclosure to the wall, make sure to seal around the sensor and wall except from the bottom.
- The sensor should be secured to the base as shown in Figure 2.
- Connect the sensor wires to the upper terminals.
- Connect the extension cable wires to the lower terminals.
- Screw the Sensor Enclosure Cover to the Base.
- When the control is powered, check for sensor temperature reading.

⚠ ALERT

Determining the proper location for the Outdoor Sensor is very important. The heating control will base its operation on the outdoor temperature information it receives from this location. If the sensor is in the sun or covered with ice, its reading will be different from the actual outdoor temperature.

Strap-On Sensor Installation

- For accurate system temperature reading, place the sensor approximately 10' feet past the last heating/cooling unit on the common supply header before any takeoffs.
- Insert the sensor in the middle bottom opening making sure that the concave side of the sensor is facing and touching the pipe.
- Use the provided tie-wraps to hold the sensor and base in place while tying it to the pipe as shown in Figure 3.
- Connect the sensor wires to the upper terminals as show in Figure 3.
- Snake the extension cable through the bottom knockouts and connect the wires to the lower terminals.
- Screw the Sensor Enclosure Cover to the Base.
- When the control is powered, check for sensor temperature reading.

Temperature Sensor Ohm Values

TEMPERATURE (in Degrees °F)	Value (in Ohms)	TEMPERATURE (in Degrees °F)	Value (in Ohms)
-30	117720	100	2914
-20	82823	110	2332
-10	59076	120	1879
0	42683	130	1524
10	31215	140	1243
20	23089	150	1021
25	19939	160	842
30	17264	170	699
35	14985	180	583
40	13040	190	489
45	11374	200	412
50	9944	210	349
55	8714	220	297
60	7653	230	253
70	5941	240	217
80	4649	250	187
90	3667		

Troubleshooting

Display shows Sensor OPEN

Check the sensor is connected and the wires are continuous to the control. Short the sensor terminals at the control. The display should read **SHORT**. If it does not, the control may be damaged.

Display shows Sensor SHORT

Remove the wires from the sensor terminals. The display should change to read **OPEN**. If it does not, the control may be damaged.

Display shows an Incorrect Temperature Display

Remove the wires from the input terminals. The display should change to read **Open**. If it doesn't, the control may be damaged. Otherwise, take an ohm reading across the detached sensor wires. The ohm reading should correspond to the Temperature Sensor Ohm Values Table. If the difference is within 5°F adjust the Trim of the sensor. Otherwise, the sensor may be damaged.