

# HEAT-TIMER

## Multi-MOD

### Extension Module Addendum

#### Providing up to 12 Stages of Full Modulation Control

The Extension Module (EXM) increases the number of stages a Multi-MOD can control from 4 to 12. All logic, memory, and control algorithms reside in the Multi-MOD panel. The Multi-MOD panel directly controls four built-in stages. When an EXM is connected to the Multi-MOD, the Multi-MOD will automatically recognize eight additional stages. Any of the twelve stages can be the lead stage and automatic rotation provides even wear among all active stages.

The EXM can be equipped with up to four output cards, each of which controls a pair of stages. There are two types of output cards: 135Ω cards control up to two fully modulating 135Ω stages, and Current/Voltage cards can be programmed to control two 0-5V, 1-5V, 0-10V, 2-10V, or 4-20mA stages. To select the type of output for Current/Voltage cards, follow the directions in the Multi-MOD I/O Manual (System Startup, Selecting the Output Type, pg. 14).

Each new stage must also be configured for its Mode (Auto, Manual, Standby, On, and Off), Ignition Start Point, and Modulation Start Point as described in the Multi-MOD I/O manual (Stage Settings, pg. 24-26). All other steps and procedures to configure the Multi-MOD presented in its I/O manual must be completed to insure smooth operation of a Multi-MOD/EXM system.

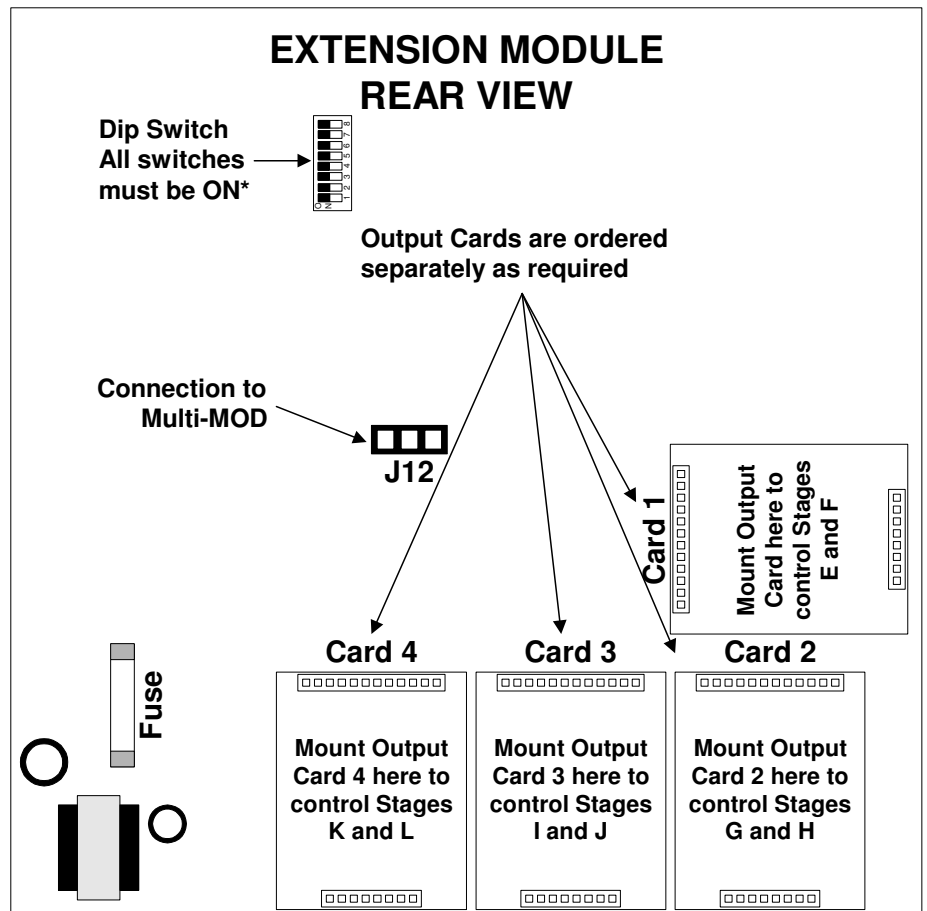

\* CAUTION: Each of the eight dip switches comes factory set in the ON position. DO NOT change these factory default settings. If any switch is set to the OFF position, erratic operation will occur.

# INSTALLATION

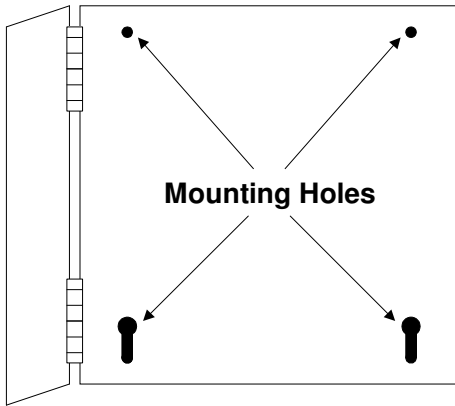

## Mounting the EXM

- Select a location adjacent to the Multi-MOD control and within the reach of the provided Panel-to-Panel cable.
- Remove the EXM panel from the metal enclosure by removing the top center screw and loosening the two bottom screws. Lift the panel out.
- Screw the enclosure to the surface through the mounting holes in the back of the enclosure.

## Mounting the Output Cards

- The Output Cards are mounted on the rear of the EXM (see front page).
- Each Output Card controls two stages. The two stages connected to one Output Card must have the same type of output (135Ω, 0-5V, 1-5V, 0-10V, 2-10V, or 4-20mA). However, different types of Output Cards can be combined on the EXM, and each Output Card can be programmed differently.
- Align the Output Card with the pins on the back of the panel and gently press them on until the top of the pins appear through the Output Card connector.

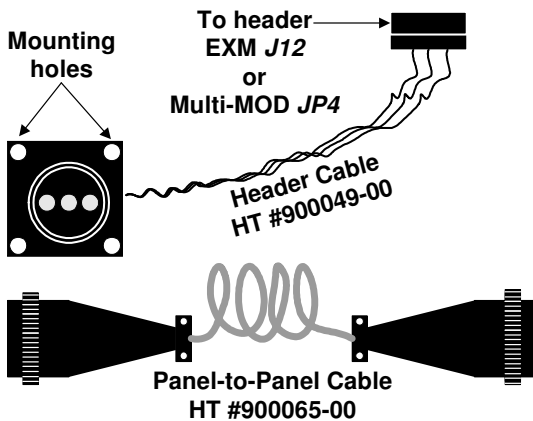

## Attaching the Connecting Cable to the EXM

- Disconnect the Panel-to-Panel cable from the two Header cables.
- Remove a Knockout (KO) from the enclosure.
- Insert the end of the Header cable with three screw terminals through the KO into the interior of the enclosure.
- Use the mounting holes to secure the square end of the Header cable to the enclosure.
- Connect the three screw connector to the black header on the rear of the EXM marked *J12* (see diagram on first page).
- Return the panel to its enclosure, replace the top screw, and tighten the bottom two screws.

## Attaching the Connecting Cable to the Multi-MOD

- Remove the Multi-MOD from its enclosure.
- Secure the remaining Header cable to the enclosure as described above.
- On the rear of the Multi-MOD, locate *JP4* and attach the three screw terminal connector.
- Return the panel to its enclosure, replace the top screw, and tighten the bottom two screws.
- Reattach the Panel-to-Panel cable to the Header cables.

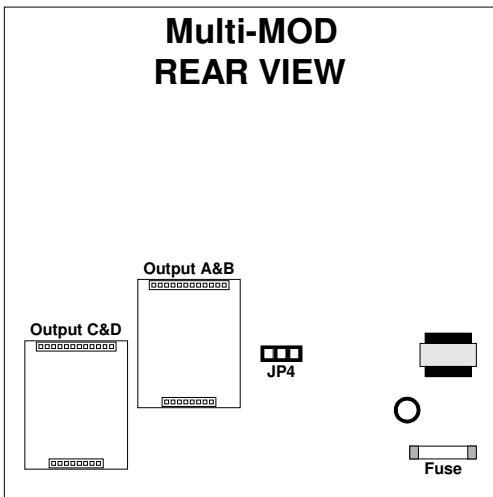

## Wiring the power

- Bring the 120VAC 60Hz power wires through a bottom KO of the enclosure. The right front KO is preferred.
- Class 1 voltages must enter the enclosure through a different opening from any Class 2 voltage wiring.
- Connect the hot line to terminal marked *LINE*.
- Connect the neutral line to the terminal marked *NEUT*.
- The green ground screw **MUST** be connected to earth ground.

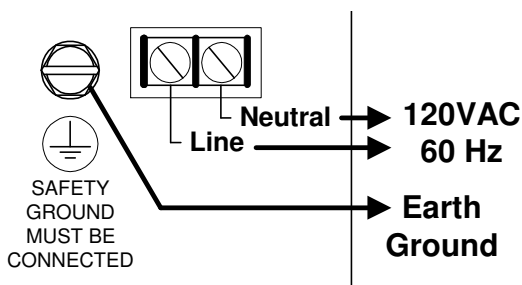

## Installing the Output Relays

- Each output stage (*E* through *L*) which is to be used must have a relay installed in the socket. These relays are ordered separately (HT #500031-00).
- To install a relay, orient the pins and then press it gently into the appropriate socket.

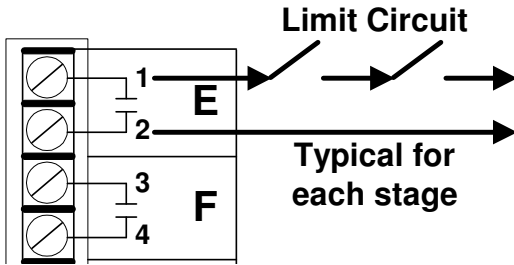

- Any stage output which does not have a relay must have its Mode set to *Off* (see Multi-MOD I/O manual, Stage Settings, pg. 24-26).

### Wiring the Stage Outputs

- Each Stage output (*E* through *L*) has one Normally Open (N.O.) relay contact.
- The N.O. contacts are dry contacts only. They do not source any voltage.
- Each N.O. contact is capable of switching 6A resistive at 120VAC.
- Total output of all stages must not exceed 15A.
- Wire the N.O. relay contacts in series with the unit's limit circuit.
- Class 1 voltages must enter the enclosure through a different opening from any Class 2 voltage wiring.

### Wiring to 135Ω Modulating Motors

- The EXM can be equipped to operate up to eight 135 Ω modulating motors.
- Each pair of stages, E&F, G&H, I&J, and K&L, are controlled by one output board.
- Wire as shown below.

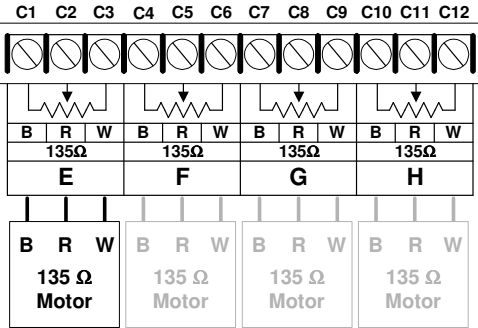

### Wiring to Current Controlled Modulating Motors

- The EXM can be equipped to operate up to eight 4-20 mA modulating motors.
- To program the control for 4-20 mA output, see the Multi-MOD I/O manual (Multi-MOD I/O Manual, System Startup settings, pg. 14).
- Apply the supplied label marked 4-20 mA below the output terminals.
- Each pair of stages, E&F, G&H, I&J, and K&L, are controlled by one output board.
- The EXM sources 24VDC excitation voltage for the 4-20mA signal.
- Wire as shown in the below.

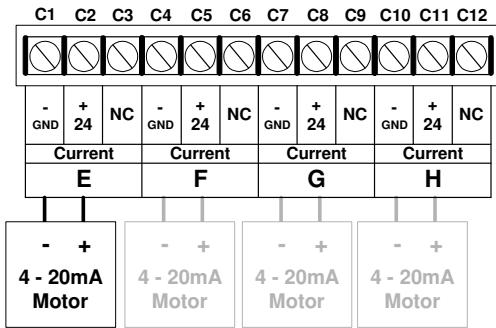

### Wiring to Voltage Controlled Modulating Motors

- The EXM can be equipped to operate up to eight 0-5 V, 0-10V, 1-5V, or 2-10V modulating motors.
- To select the range, 0-5V, 0-10V, 1-5V or 2-10V, see the Multi-MOD I/O manual (Multi-MOD I/O Manual, System Startup settings, pg. 14).
- Apply the supplied label marked Voltage below the output terminals.
- Each pair of stages, E&F, G&H, I&J, and K&L, are controlled by one output board.
- Wire as shown below.

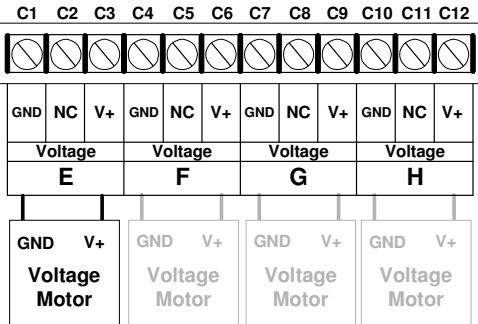

	135						
	Common	Increase Mod	Decrease Mod	Signal Sink (GND)	24V Source (+)	V+	GND
Stage E	C2	C3	C1	C1	C2	C3	C1
Stage F	C5	C6	C4	C4	C5	C6	C4
Stage G	C8	C9	C7	C7	C8	C9	C7
Stage H	C11	C12	C10	C10	C11	C12	C10
Stage I	C14	C15	C13	C13	C14	C15	C13
Stage J	C17	C18	C16	C16	C17	C18	C16
Stage K	C20	C21	C19	C19	C20	C21	C19
Stage L	C23	C24	C22	C22	C23	C24	C22

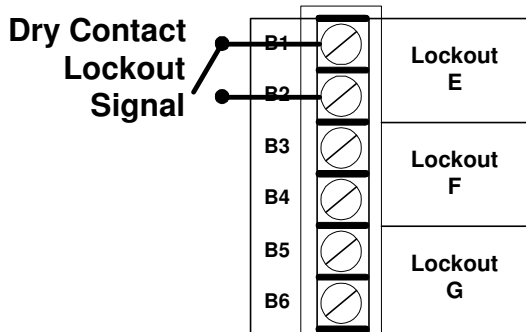

## Wiring the Lockout Inputs

- A closure across the pair of EXM *LOCKOUT INPUT* terminals informs the Multi-MOD that the particular stages's boiler, chiller, etc. has encountered a safety limit and can not be restarted without a manual reset. The Multi-MOD will not activate or modulate a Stage in Lockout.
- A pair of *LOCKOUT INPUT* terminals is provided for each stage.
- The Lockout signal must be a dry contact closure from the boiler, chiller, etc. controlled by that stage's output.
- The *LOCKOUT INPUTS* are dry contacts only. No voltage can be placed across the terminals.
- Wire the Lockout signals to their respective *STAGE* terminals:
  - *STAGE E* to Lockout Input terminals *B1* & *B2*
  - *STAGE F* to Lockout Input terminals *B3* & *B4*
  - *STAGE G* to Lockout Input terminals *B5* & *B6*
  - *STAGE H* to Lockout Input terminals *B7* & *B8*
  - *STAGE I* to Lockout Input terminals *B9* & *B10*
  - *STAGE J* to Lockout Input terminals *B11* & *B12*
  - *STAGE K* to Lockout Input terminals *B13* & *B14*
  - *STAGE L* to Lockout Input terminals *B15* & *B16*

## OPERATION

### EXM Status Lights

- Whenever the EXM is powered, the red LED marked *POWER*, located in the upper left of the panel, should be lit. If it is not, check the 120VAC power source.
- If the EXM is correctly connected to a powered Multi-MOD, the green LED marked *COMM ERROR* will blink on and off, approximately once a second. If the light is does not blink, check the connecting cables.
- If the N.O. contacts of a Stage relay are energized, the red LED immediately to the left of the relay will be on. If the relay is not energized, the red LED will be off.

### Display Stage Status

- The percent modulation and Mode of each stage is displayed on the main screen of the Multi-MOD control. Stages in the Automatic mode which are not active show ---.
- The default screen shows Stages A through D. Simply rotate the *ADJUST* knob clockwise (without pressing) to see the remaining Stages, E through L.
- Rotate the *ADJUST* knob counterclockwise to go back in the Stage order.
- Stages A through D correspond to the Stages marked A through D on the Multi-MOD panel.
- Stages E through L correspond to Stages of the EXM.

140°F			
<A>	B	C	D
100%	100%	100%	100%



140°F			
E	F	G	H
100%	61%	---	---



140°F			
I	J	K	L
Off	Off	Off	Off

### Stage Settings

- All Stage setting are made at the Multi-MOD panel.
- If the *COMM ERROR* LED is flashing, the Multi-MOD recognizes the EXM panel and all its Stages.
- Carefully follow all the steps in the Multi-MOD I/O manual (Stage Settings, pgs. 24-26) to set up Stages E through L.

**WARNING: Each Stage, A through L MUST be setup properly. Failure to do so will result in erratic set point control and may cause system damage.**

Heat-Timer Corporation  
 20 New Dutch Lane  
 Fairfield, NJ 07004  
 Phone (973)575-4004 Fax (973)575-4052  
<http://www.heat-timer.com>