

## INSTALLATION

# NETWORK STACK SENSOR

### Mount the Sensor

- Up to 1500' from the panel (see specification on opposite page).
- Drill a 1/2" hole through the stack wall for the bushing.
- Screw the sensor plate to the stack through the four screw holes.
- Push the sensor probe through the bushing into the stack.
- Run the high temperature wire through one of the knockouts (KO) of the handybox.
- The sensor is provided with high temperature wire. This wire can not be cut or spliced until it has been run to a location where the temperature does not exceed 130°F. Once the high temperature wire has been run to this lower temperature area, the wire can be extended up to 500' with 18 gauge shielded wire.

**WARNING: DO NOT install the Transmitter module on the stack. DO NOT cut or splice the high temperature wire provided with the sensor until it has been run to an area where the temperature will not exceed 130°F.**

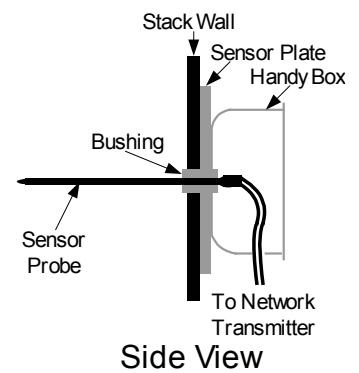
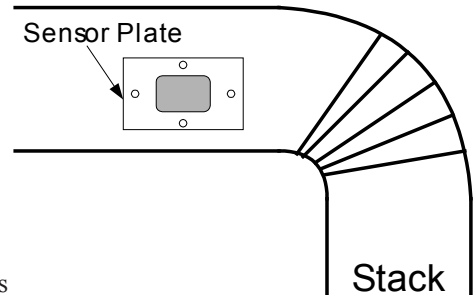

### Wiring the Transmitter

- The Transmitter labeled *Platinum Sensor Network Transmitter* can be installed in any convenient location where the temperature will not exceed 130°F.
- Remove the cover from the Transmitter. The circuit board shown at right is on the inside of the cover.
- Bring the sensor wires through a KO into the *Sensor Terminals*, labeled as X1, X2.
- Bring the 2-wire unshielded twisted pair (see next page for network wiring) through a KO into the *Network Terminals*.
- Screw the cover back on the handybox.
- Each sensor has a specific ID number. The ID number is on the back of the sensor, and is on the Network Identification card which is provided with each sensor.
- After installing the sensor, fill out its location on its Network Identification card.

**IMPORTANT:** Do fill out the Network Identification card. Otherwise it will be very difficult to configure the sensors.

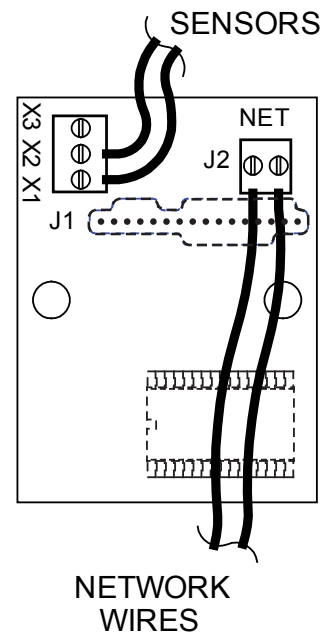

## Network Wiring

- To power the network it is necessary to have a Network Power Supply (HT#926670). One network power supply is sufficient to power up to 32 network sensors.
- Use 2-wire **unshielded twisted pair** (see specification below).
- There is no polarity to observe. Either network wire from a sensor can be attached to panel terminal *A* or *B*.
- The wires can be run in virtually any configuration. They can be wired sensor to sensor (daisy chained as shown). They can be wired in a star configuration, with each sensor pair brought back to the panel. Finally, there can be any combination of the two.

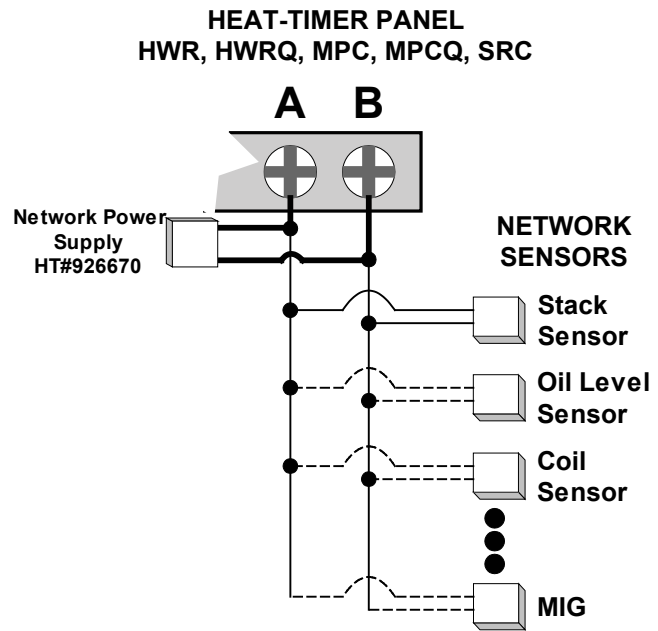

Wire	Type	Gauge	Maximum Length (ft)	Maximum Temp (°F)
Belden 8471	Unshielded twisted Pair	16AWG	1200	140
Belden 85102	Unshielded twisted Pair	16AWG	1200	185

## Troubleshooting

### Sensors registering DISCONNECTED

- Test for voltage at the Transmitter *Network Terminals* (see diagram previous page). When the Transmitter is connected to the network, there should be between 35 and 42VDC across the two *Network Terminals*.
- If voltage is too low, check the Network Power Supply as described in its I/O manual.

### Sensors registering OUT OF RANGE

- The network voltage must be correct as described above.
- Remove the two sensor wires from the Transmitter *Sensor Terminals* (see diagram previous page).
- Take an ohm reading across the detached sensor wires. The ohm reading should correspond to the chart at right. If it does not, check the wiring to the sensor to see if it has been damaged. If the wire is good, the sensor may be damaged.

TEMPERATURE (in Degrees °F)	Value (in Ohms)
200	1358
250	1464
275	1517
300	1569
325	1622
350	1674
375	1725
400	1773
425	1824
450	1875
475	1926
500	1977
525	2027
550	2077
575	2127
600	2174
625	2222
650	2272
675	2321
700	2370
725	2419
750	2464
800	2559
850	2655
900	2749