

# INSTALLATION/OPERATING INSTRUCTIONS

## 3-WAY RADIANT VALVE

### Pipe the Valve

- The System port, or the port on the valve which will deliver the mixed water to the system, must never be the center port.
- The motor must not be below the valve after installation.

### Orient the Valve Face Plate

- Remove the knob from the shaft of the valve.
- Select which of the four piping diagrams at the right represents your system.
- Unscrew the face plate and rotate and/or turn it over so the numbered scale is in the position shown below. Then reattach the face plate.

### Check the Motor Position

- The motor has a clear circular window. Inside the window is a raised indicator which shows what position the motor is in.
- The motor is shipped with the indicator in the middle position, directly below the red arrow on the motor.
- If the indicator is not directly under the red arrow then follow the directions for valve wiring and rotate the indicator back to the middle.

### PIPING ARRANGEMENT

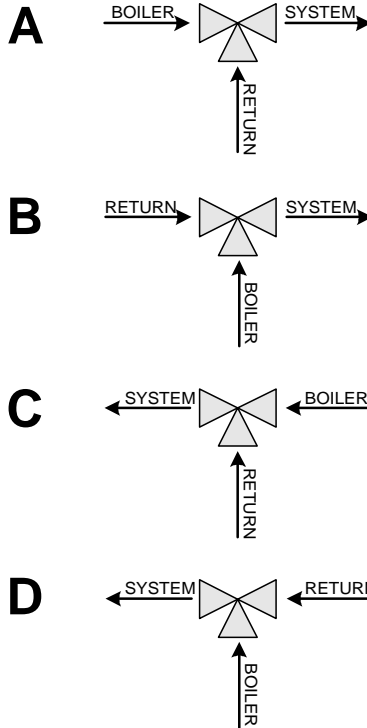

### FACE PLATE POSITION

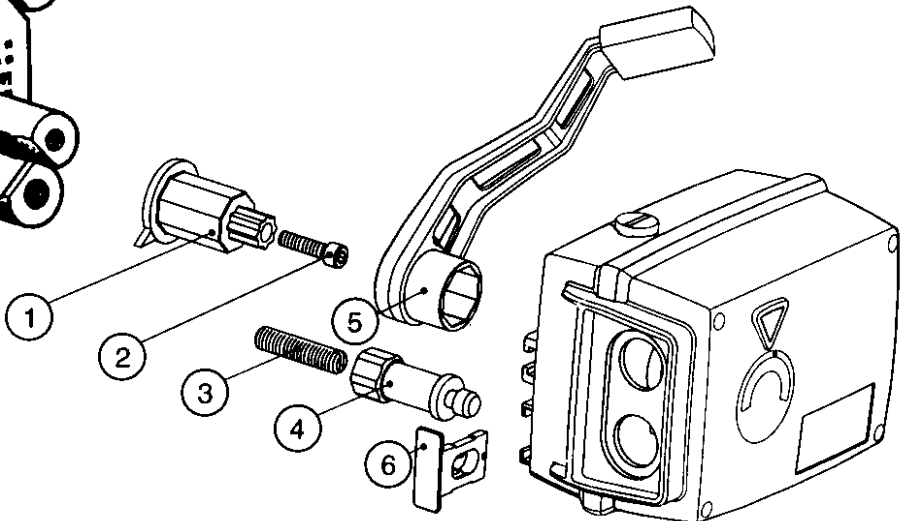
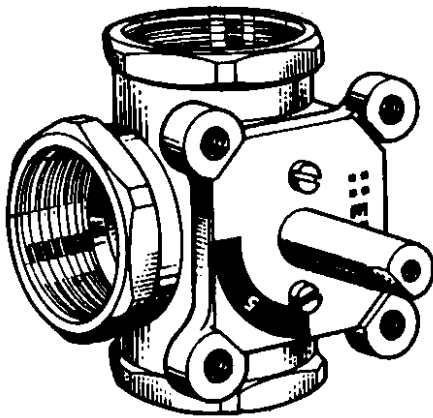
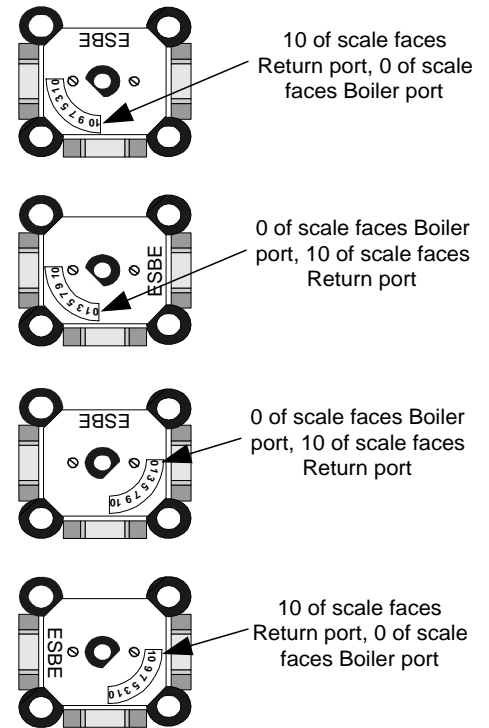

## Mount the Motor on the Valve (Numbers refer to diagram previous page)

- Slide the sleeve (1) on the valve shaft.
- Attach the sleeve to the shaft with the socket head cap screw (2). Tighten with the hex key provided.
- Rotate the sleeve until its pointer is aligned to the number 5 on the face plate scale.
- Use a screwdriver to tighten down the slotted set screw (3) into the hole in the valve next to the number 5 on the face plate.
- Screw down the mounting post (4) over the set screw. Tighten the mounting post with a wrench.
- Slide the motor lever (5) over the sleeve. The long part of the lever should extend in the opposite direction from the number 5 on the face plate. This lever can be used to manually position the valve. **DO NOT** use this lever to manually adjust the valve after the motor is installed.
- Press the motor down onto the sleeve and the mounting post.
- The black plastic locking clip (6) must be pressed in toward the motor body until it clicks into place.

## Wire the Motor

- The motor is powered with a 24VAC transformer 5VA minimum.
- Remove the motor cover to reveal the two terminal strips (see side diagram).
- The terminal marked *N* is the common terminal. Bring one side of the 24VAC power to this terminal.
- The terminal marked *L1* next to *N* will move the motor counterclockwise. To directly position the motor, place the other side of the 24VAC on this terminal. The motor position indicator will begin to rotate counterclockwise.

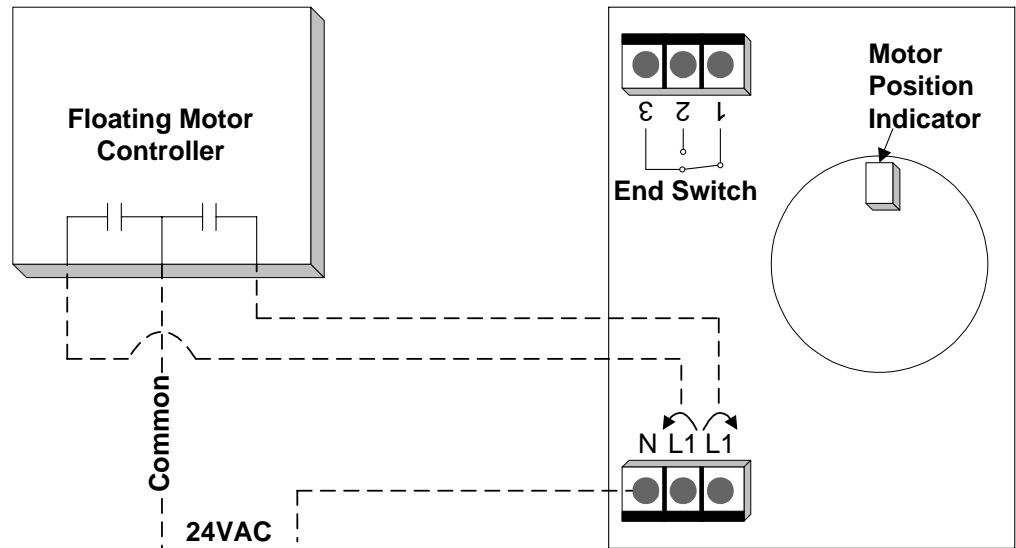

- The terminal marked *L1* closest to the motor position indicator will move the motor clockwise. To directly position the motor, place the other side of the 24VAC on this terminal. The motor position indicator will begin to rotate clockwise.
- A floating motor controller will automatically position the motor. Wire the other side of the 24VAC to the Common (usually Red) wire of the controller. The controller will then pulse the motor either clockwise or counterclockwise when wired as shown.

## End Switch

- The motor is equipped with a SPDT (single pole double throw) end switch. It is not necessary to wire to the switch. However, it can provide a dry closure whenever the valve reaches the end position.
- Contact the factory to properly adjust the end switch.

## Troubleshooting

Disconnect any wires which go to the controller. Unless the motor position indicator is in the fully counterclockwise position, place 24VAC from terminal *N* to the terminal *L1* next to it. The motor position indicator and the pointer to the face plate on the valve itself should begin to move in a counterclockwise fashion. Next, or if the motor position indicator was already fully counterclockwise, place 24VAC from terminal *N* to the terminal *L1* closest to the motor position indicator. The motor position indicator and the pointer to the face plate on the valve itself should begin to move in a clockwise fashion. In approximately 4 minutes, the indicator and pointer should have moved to the fully clockwise position. If this test is passed, the valve is working correctly, check the controller and the piping.

If the above test is not passed, remove the motor from the valve body. Rotate the lever to manually position the valve. If the lever can not be moved, contact the factory for further directions. If the lever can be moved but offers resistance, try rotating it several times to loosen any debris or corrosion on the valve.

If the valve can be manually positioned, run the original test on the motor only. If the motor position indicator does not move, it may be damaged.