

# HEAT-TIMER®

## INSTALLATION/OPERATING INSTRUCTIONS

# 2-WAY MOTORIZED VALVE

## Piping

### On/Off Applications

- The valve turns on or off the flow of steam to the system.
- The valve motor is driven from fully closed to fully open and vice versa.
- The arrow cast onto the valve should be in the direction of the steam flow.

### Modulating Applications

- The valve controls the amount of steam entering the system.
- The valve motor is modulated depending on the amount of steam the system needs.
- The arrow cast onto the valve should be in the direction of the steam flow.

### Alignment

- The valve must be piped in a vertical alignment (see diagram). The valve stem may be pointing up or down. The valve stem may even be rotated up to 45° from the vertical axis.
- The valve stem **MUST NOT** be pointing along the horizontal axis.

### Clearance

- It is necessary to leave clearance in front of the valve stem for future maintenance and servicing.
- The amount of clearance depends on the size of the valve. Leave 12" of clearance or twice the valve size, whichever is greater.

## Mounting the Motor

- The motor and linkage come pre-assembled. The linkage has been adjusted at the factory to fit the specific valve.
- Remove the cotter pin and large brass nut from the valve stem.
- Slide the end of the mounting bracket down over the valve stem.
- Hand tighten the brass nut to secure the mounting bracket to the valve stem.
- Remove the hair clips and rod which hold the clevis to the linkage.
- Screw the threaded end of the clevis down over the valve stem until the hole drilled in the clevis and the hole drilled in the valve stem line up.
- Insert the cotter pin through the clevis **AND** the valve stem.
- Reattach the clevis to the linkage using the rod and hair clips.
- Tighten the jam nut against the bottom of the clevis.

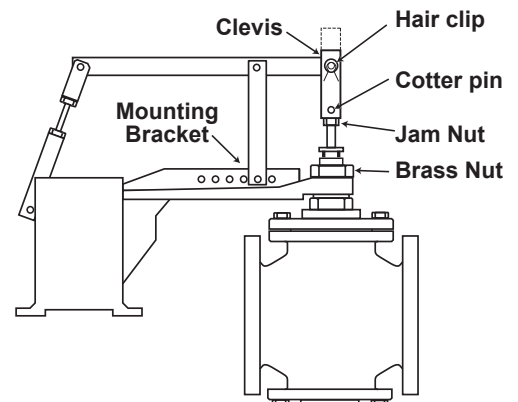
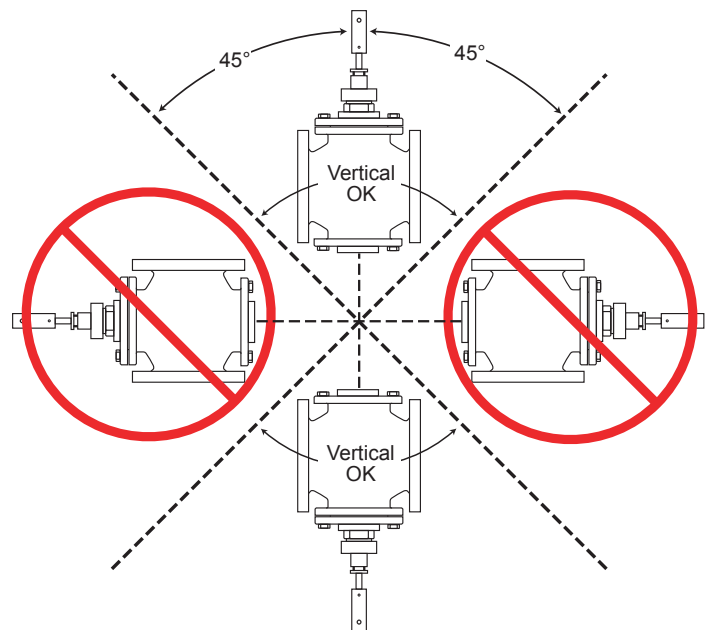
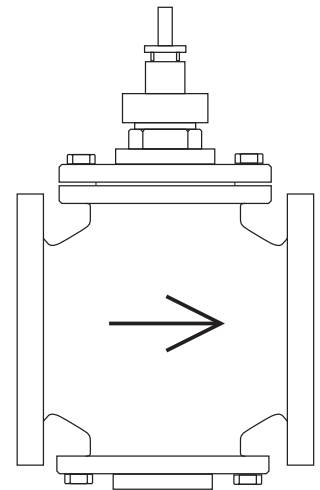

# Wiring the Motor

- The valve motor is a floating type of motor.
- The motor is to be powered with the transformer provided.
- Remove the cover of the motor to reveal the terminal strip.
- The black and white wires on the transformer are wired to 115VAC. Black is wired to hot. White is wired to neutral.
- Wire Terminal (1) on the Motor terminal strip to one of the Transformer screw marked LOAD.
- Wire the Second Transformer terminal marked LOAD to and to the COMMON on the Heat-Timer Platinum Panel.
- Wire Terminal (3) on the motor to the terminal of the control marked either B or CLOSED.
- Wire Terminal (4) on the motor to the terminal of the control marked either W or OPEN.
- DO NOT use terminals 5 and 6 on the Motor Terminal Block.
- Screw the cover back onto the motor.

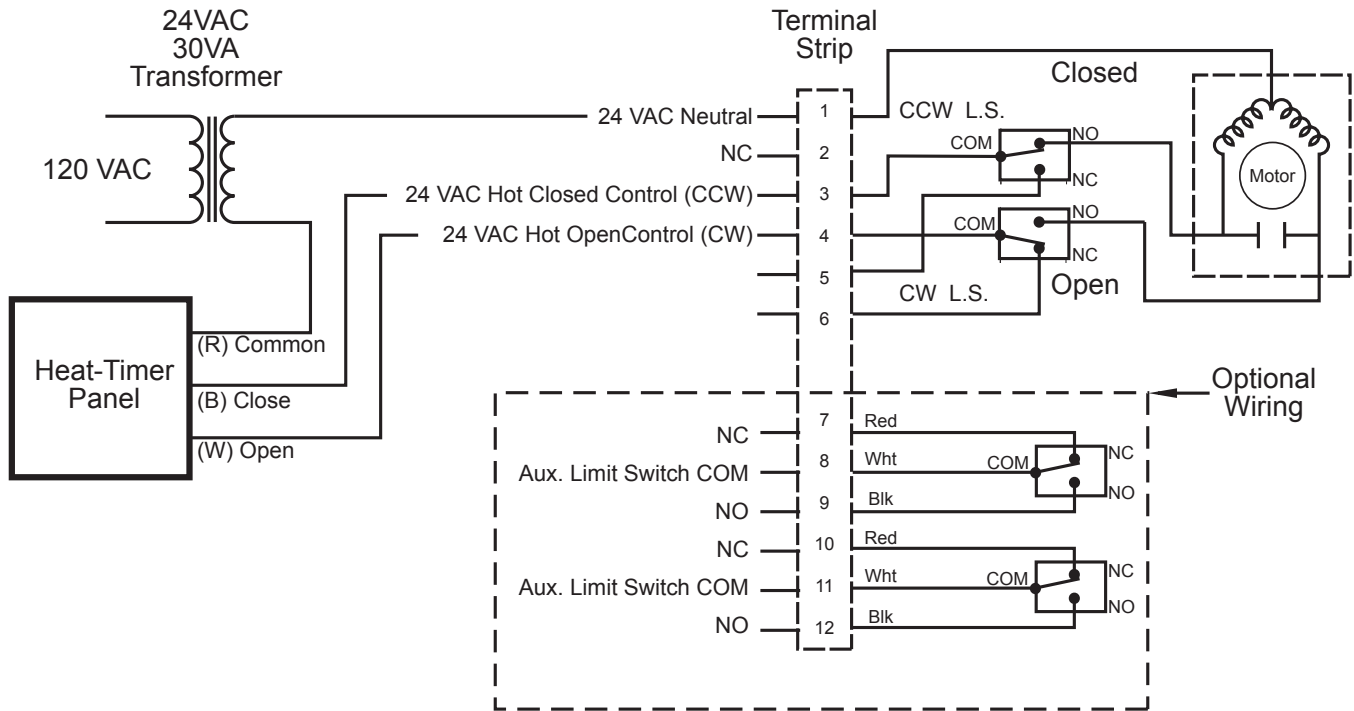

# Testing the Motor

- First test if there is 24VAC to Terminal (1) on the motor and the COMMON or R terminal on the Panel (as described above). If there is not, check the transformer and wiring.
- To test if the motor closes, place a jumper from the COMMON (R) Panel terminal to the CLOSE (B) Panel terminal. The motor should begin to close the valve. It may take the entire motor time (2 or 6 minutes) for the valve to fully close.
- To test if the motor opens, place a jumper from the COMMON (R) Panel terminal to the OPEN (W) Panel terminal. The motor should begin to open the valve. It may take the entire motor time (2 or 6 minutes) for the valve to fully open.
- If the motor can be closed and opened as described above, the motor is working correctly.